

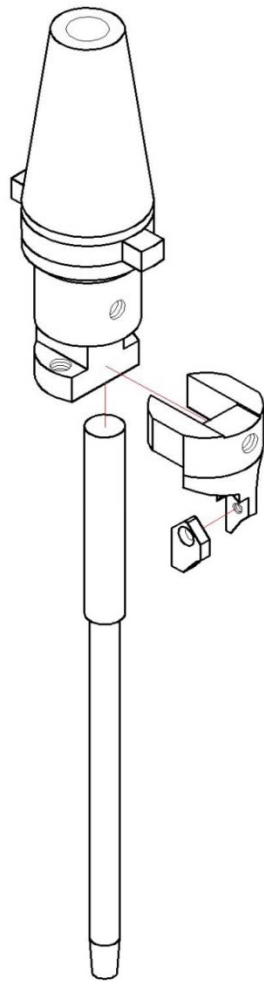

PRO VALVE

TOOLING CATALOG



CONTENTS

CUTTING SYSTEM TOOLING RANGE FOR SEATS MACHINING..... 1-6

-SH-100	1
-SH-102	2
-SH-200	3
-SH-300	4
-SH-400	5
-SH-500	6

SPECIAL CUTTING SYSTEM TOOLING RANGE FOR SEATS MACHINING..... 7-10

-SH-100,SH-102,SH-200 (Counterboring)	7
-SH-300 (Single angles)	8
-SH-400 (Single angles)	9
-SH-500 (Single ,angles)	10

SPECIAL TOOL HOLDERS 11-13

-DMH-2	11
-MAT-20	12
-MAC-45	13

CARBIDE CUTTING BITS 14-19

-3 ANGLE CARBIDE CUTTING BIT 45°	14 - 15
-3 ANGLE CARBIDE CUTTING BIT 30°	16 - 17
-SPECIAL 3 ANGLES CARBIDE BIT	18
-SINGLE ANGLE CARBIDE CUTTING BIT	19

CARBIDE PILOTS 20-38

- CP CARBIDE PILOT	20
- CPL CARBIDE PILOT	21
- CPXL CARBIDE PILOT	22
- CPB CARBIDE PILOT	23

CUTTING SYSTEM TOOLING RANGE FOR SEATS MACHINING

SH-100

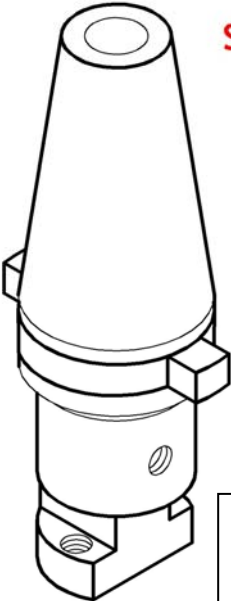

Fork width : 12mm
Fork height: 9.5mm
Pilot hole : Ø9.52mm

CP

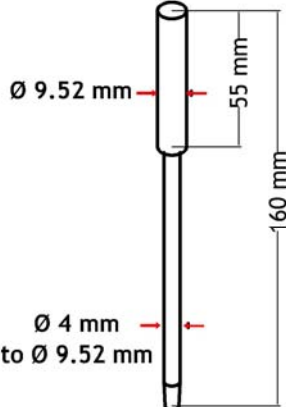

CPL

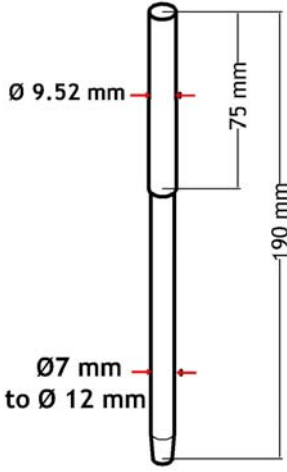

SH-0L

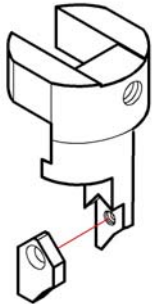

Diameter capacity of valve seat
Ø16 – Ø30 mm

Long type

SH-0



Diameter capacity of valve seat
Ø16 – Ø30 mm

SH-1

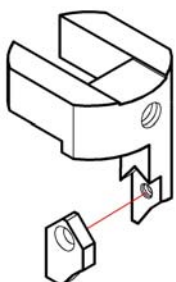

Diameter capacity of valve seat
Ø28 – Ø42 mm

SH-2

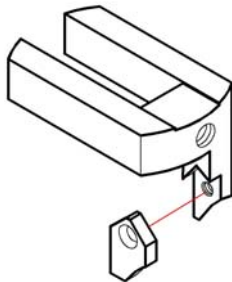

Diameter capacity of valve seat
Ø40 – Ø58 mm

CUTTING SYSTEM TOOLING RANGE FOR SEATS MACHINING

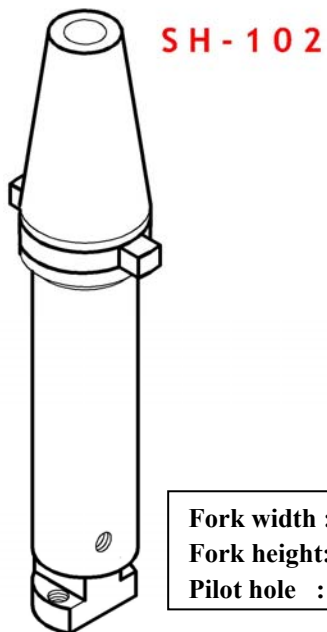

Fork width : **12mm**
 Fork height: **9.5mm**
 Pilot hole : **Ø9.52mm**

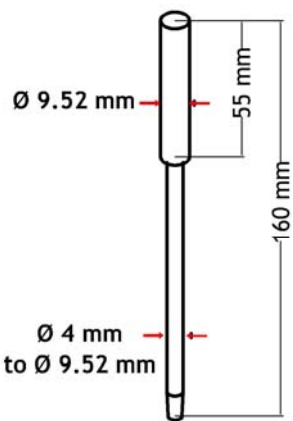

CP

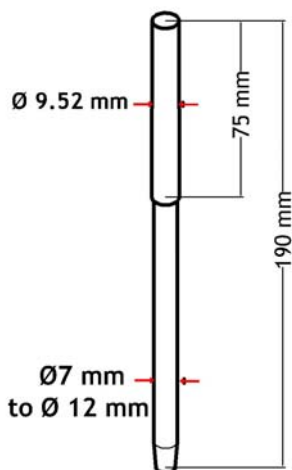

CPL

SH-0L

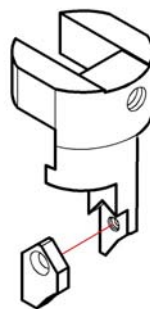

Long type

Diameter capacity of valve seat
Ø16 – Ø30 mm

SH-0

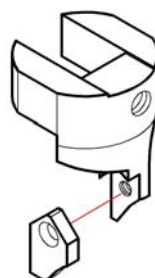

Diameter capacity of valve seat
Ø16 – Ø30 mm

SH-1

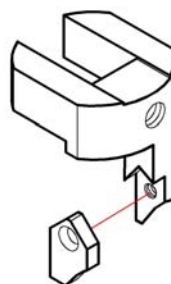

Diameter capacity of valve seat
Ø28 – Ø42 mm

SH-2

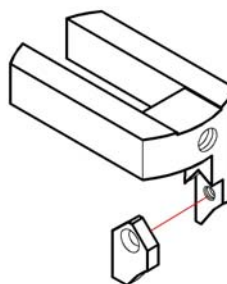

Diameter capacity of valve seat
Ø40 – Ø58 mm

CUTTING SYSTEM TOOLING RANGE FOR SEATS MACHINING

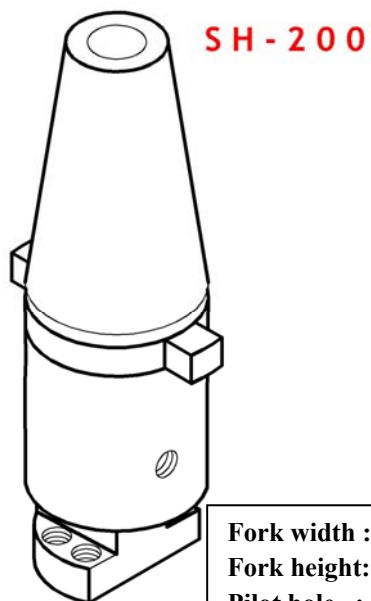

Fork width : **12mm**
 Fork height: **9.5mm**
 Pilot hole : **Ø9.52mm**

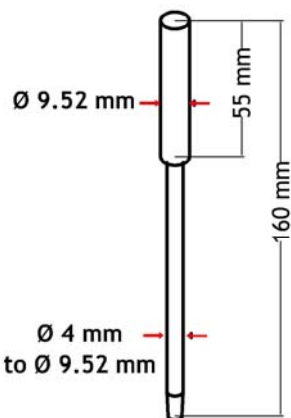

CP

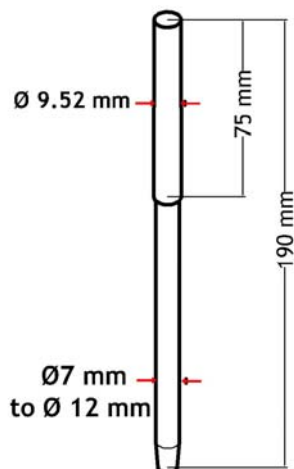

CPL

SH-0L

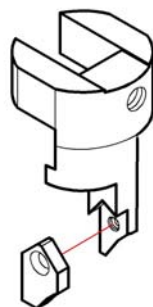

Long type

Diameter capacity of valve seat
Ø16 – Ø30 mm

SH-0

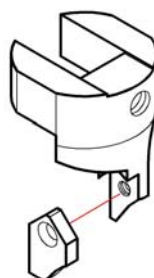

Diameter capacity of valve seat
Ø16 – Ø30 mm

SH-1

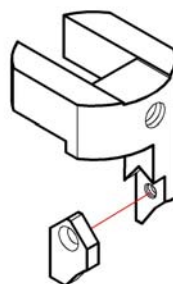

Diameter capacity of valve seat
Ø28 – Ø42 mm

SH-2

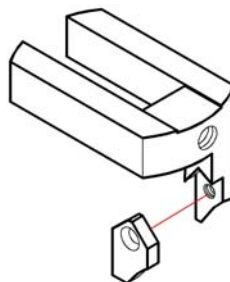

Diameter capacity of valve seat
Ø40 – Ø58 mm

CUTTING SYSTEM TOOLING RANGE FOR SEATS MACHINING

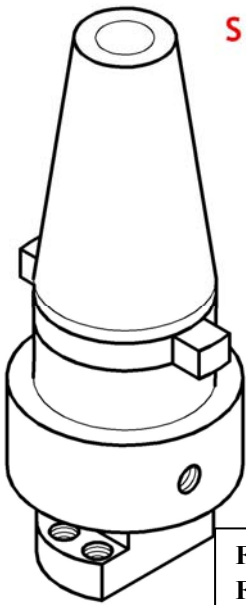

SH-300

Fork width : **14mm**
Fork height: **11mm**
Pilot hole : **Ø9.52mm**

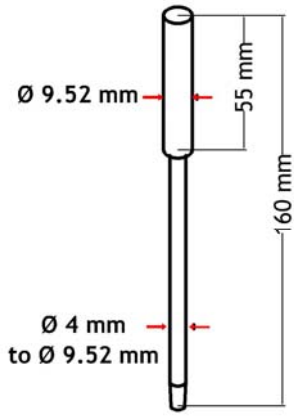

CP

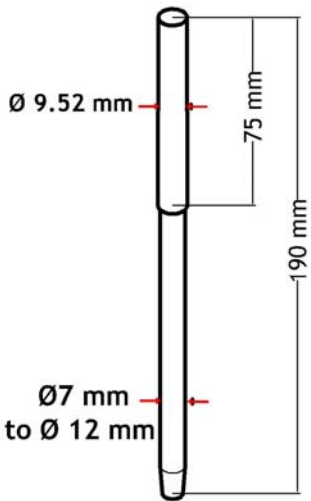

CPL

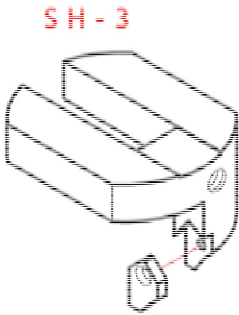

SH-3

Diameter capacity of valve seat
Ø40 – Ø70 mm

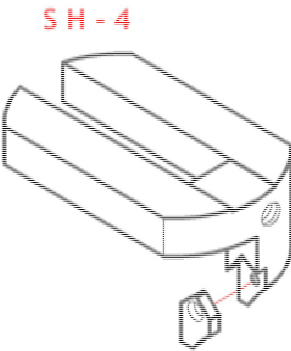

SH-4

Diameter capacity of valve seat
Ø45 – Ø90 mm

CUTTING SYSTEM TOOLING RANGE FOR SEATS MACHINING

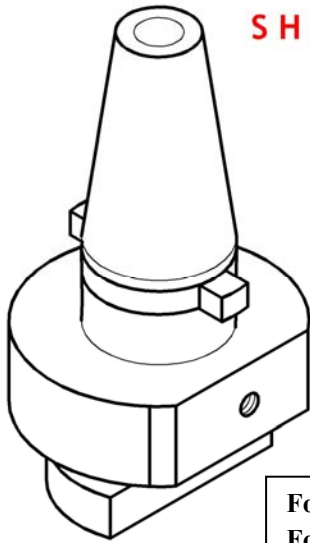

SH-400

Fork width : **14mm**
Fork height: **11mm**
Pilot hole : **Ø9.52mm**

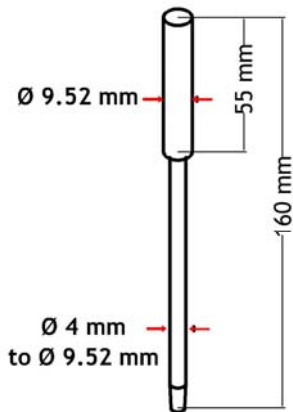

CP

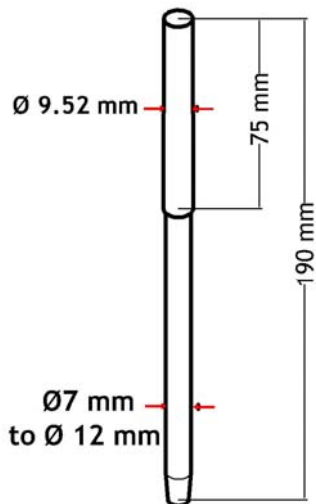

CPL

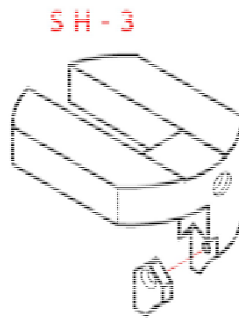

SH-3

Diameter capacity of valve seat
Ø45 – Ø75 mm

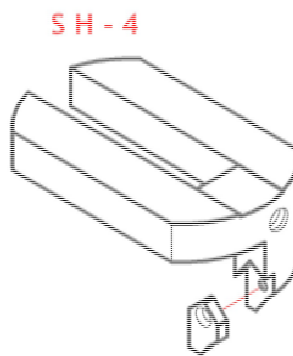

SH-4

Diameter capacity of valve seat
Ø50 – Ø100 mm

CUTTING SYSTEM TOOLING RANGE FOR SEATS MACHINING

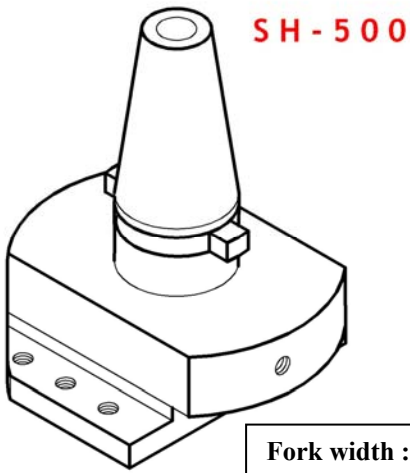

Fork width : 25mm
Fork height: 12mm
Pilot hole : Ø20mm

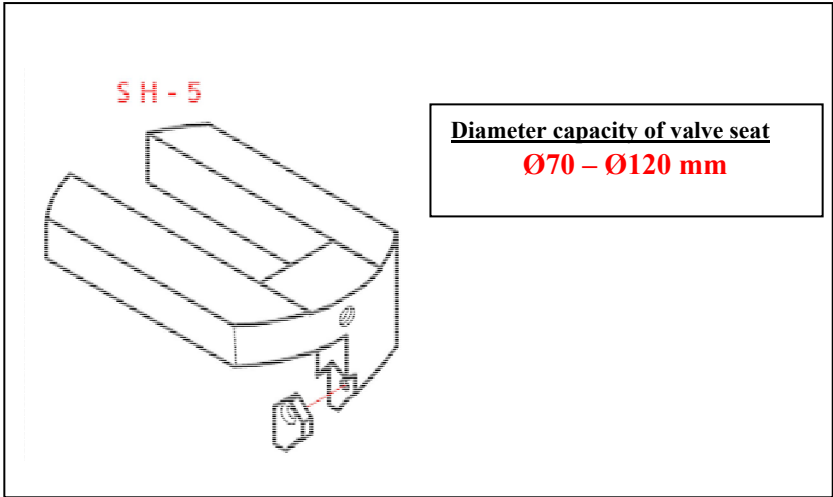
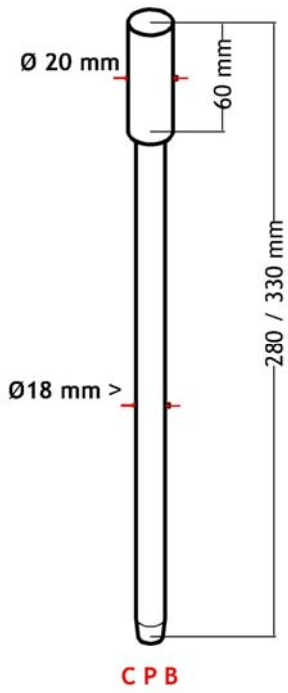

SPECIAL CUTTING SYSTEM TOOLING RANGE FOR SEATS MACHINING

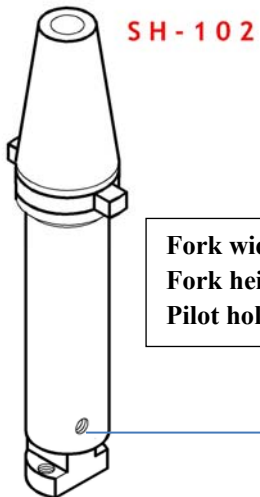
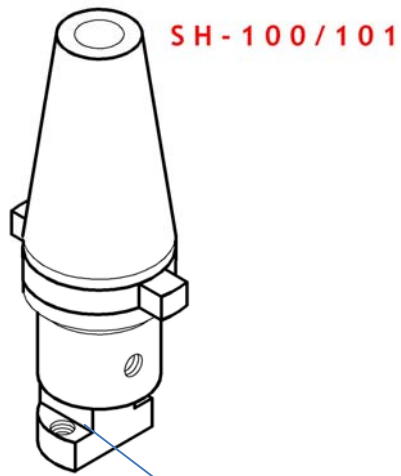

Fork width : 14mm
Fork height: 11mm
Pilot hole : Ø9.52mm

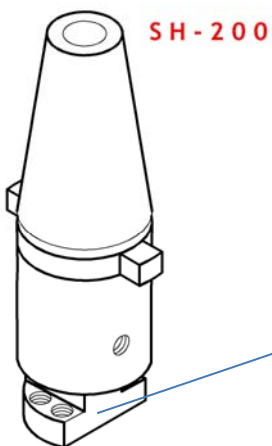

SH-190

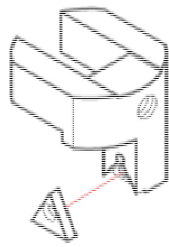

TCMT-11



SH-290

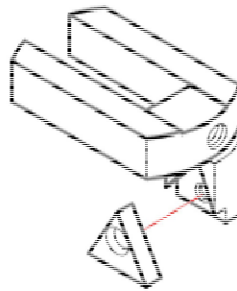

TCMT-16



SPECIAL CUTTING SYSTEM TOOLING RANGE FOR SEATS MACHINING

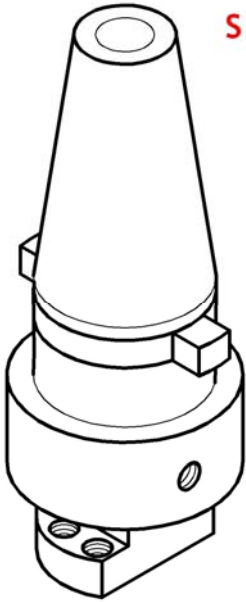

SH - 300

Fork width : 14mm
Fork height: 11mm
Pilot hole : Ø9.52mm



TCMT-16

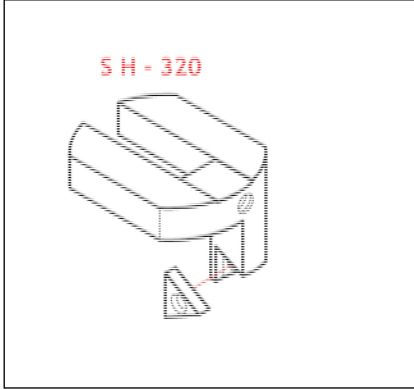

SH - 320

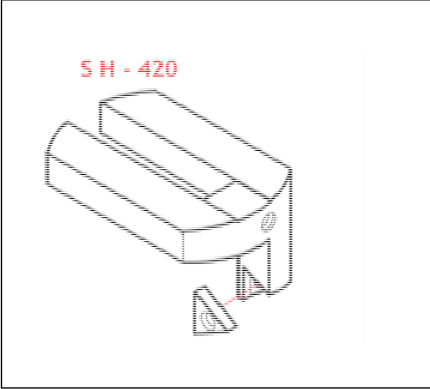

SH - 420

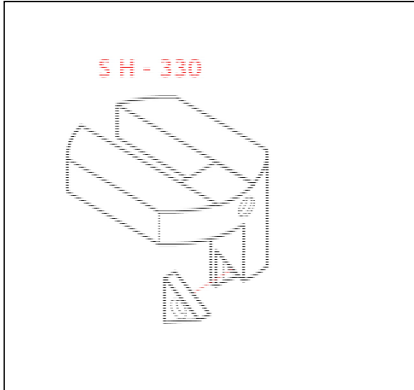

SH - 330

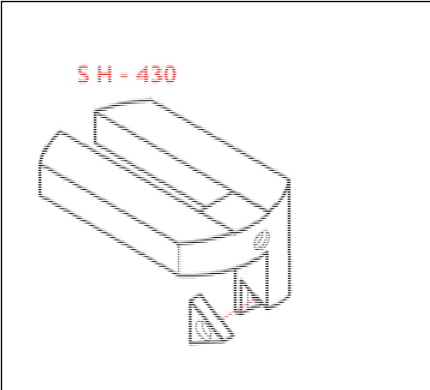

SH - 430

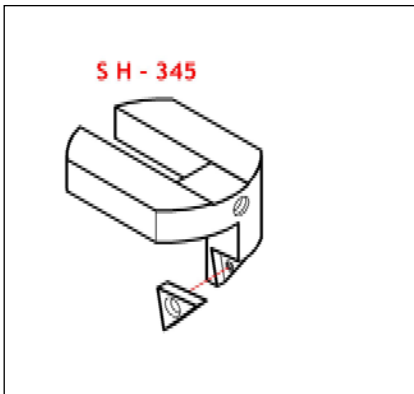

SH - 345

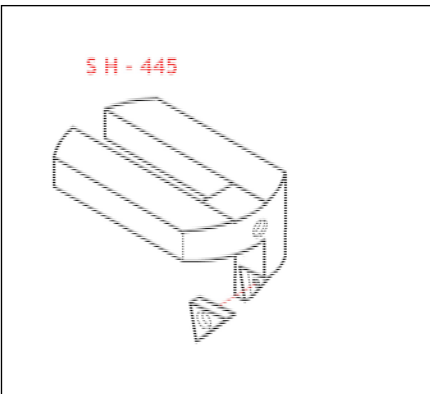

SH - 445

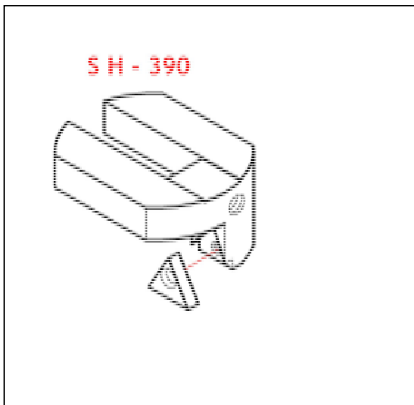

SH - 390

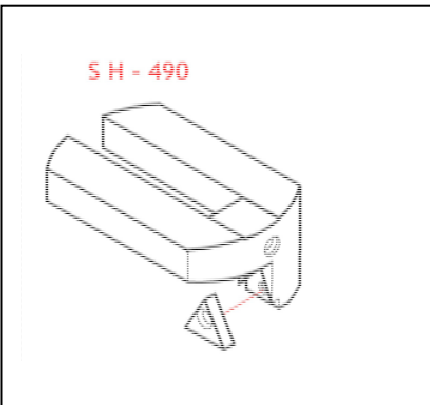

SH - 490

SPECIAL CUTTING SYSTEM TOOLING RANGE FOR SEATS MACHINING

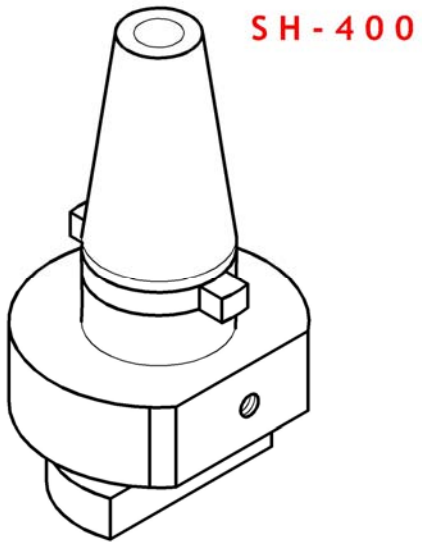

Fork width : **14mm**
Fork height: **11mm**
Pilot hole : **Ø9.52mm**

TCMT-16



SH-320

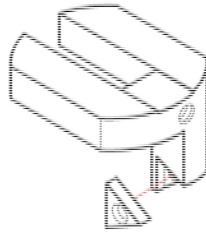

SH-420

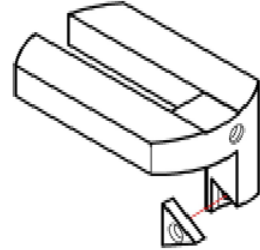

SH-330

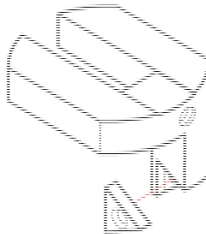

SH-430

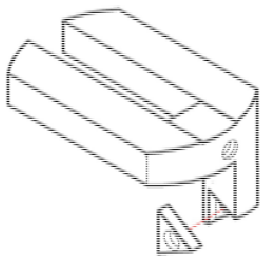

SH-345

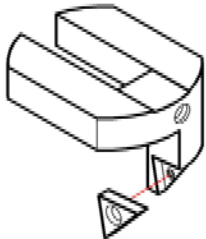

SH-445

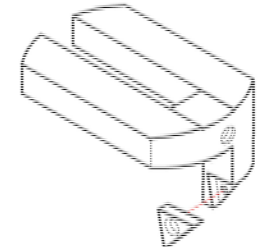

SH-390

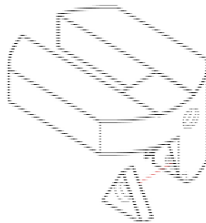

SH-490

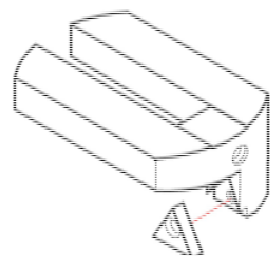

SPECIAL CUTTING SYSTEM TOOLING RANGE FOR SEATS MACHINING

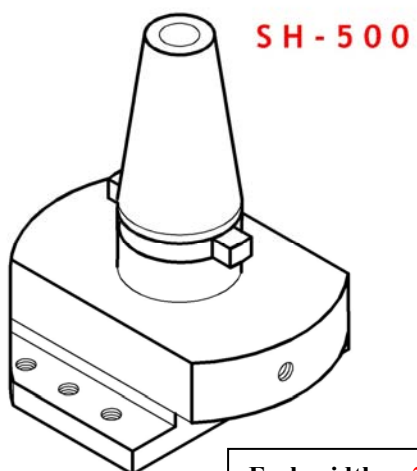

Fork width : 25mm
Fork height: 12mm
Pilot hole : Ø20mm

TCMT-16



SH-520

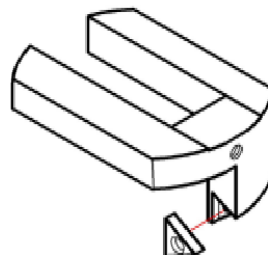

SH-530

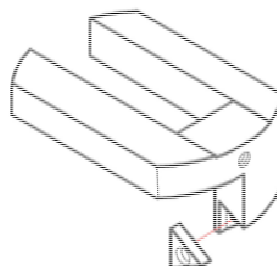

SH-545

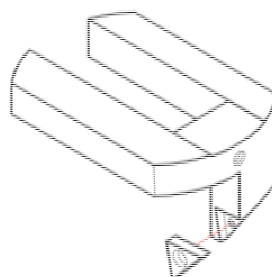

SH-590

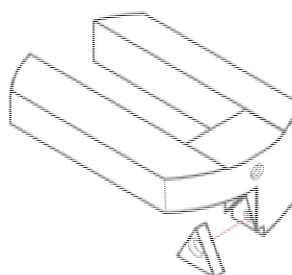

SPECIAL TOOL HOLDERS

DMH-2

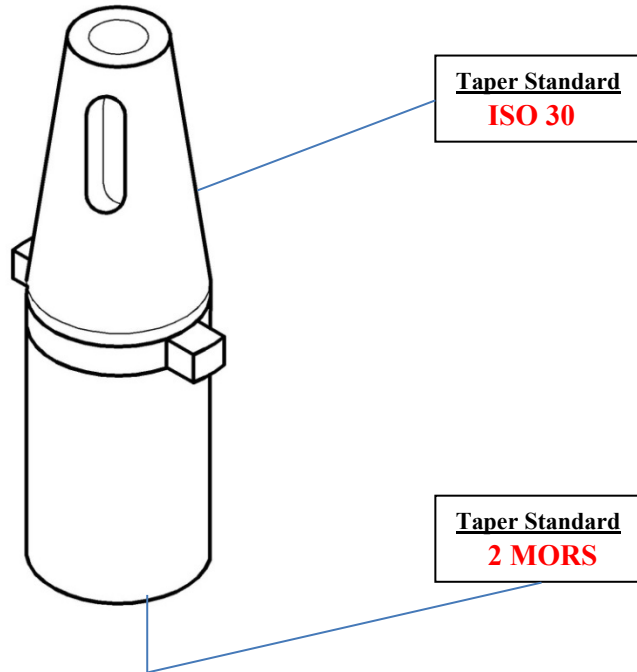

PRECISION DRILL CHUCK

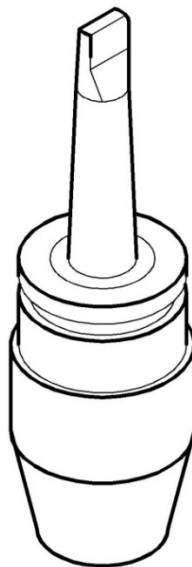

SPECIAL TOOL HOLDERS

MAT-20

MERCEDES ATEGO AXOR
(EXHAUST BRAKE VALVE SEAT)

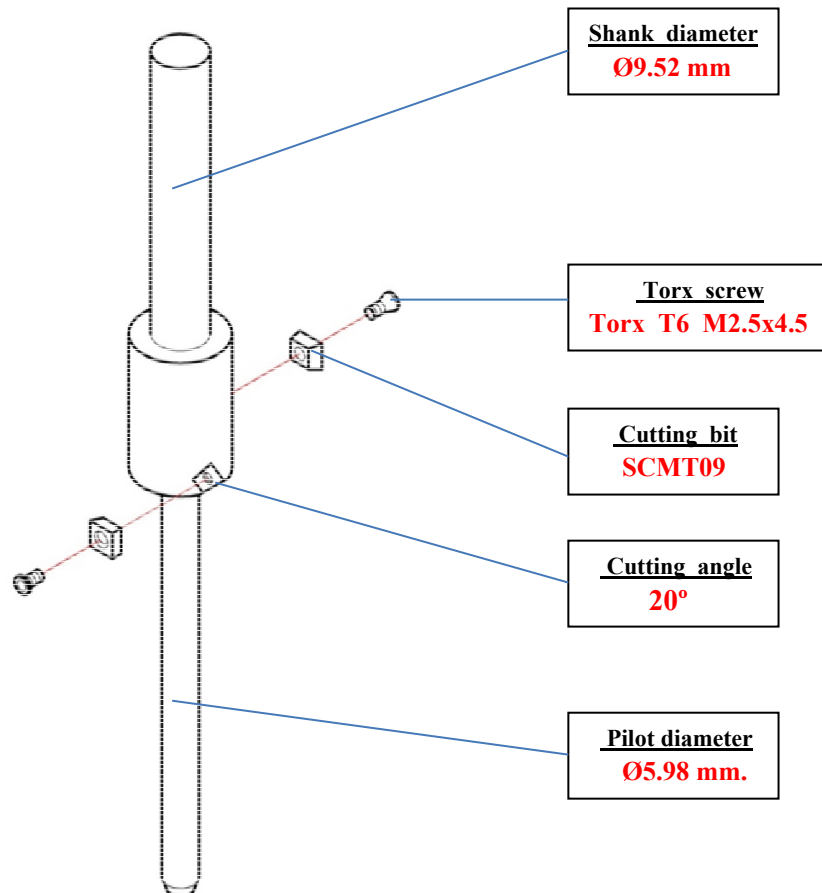



SPECIAL TOOL HOLDERS

MAC-45

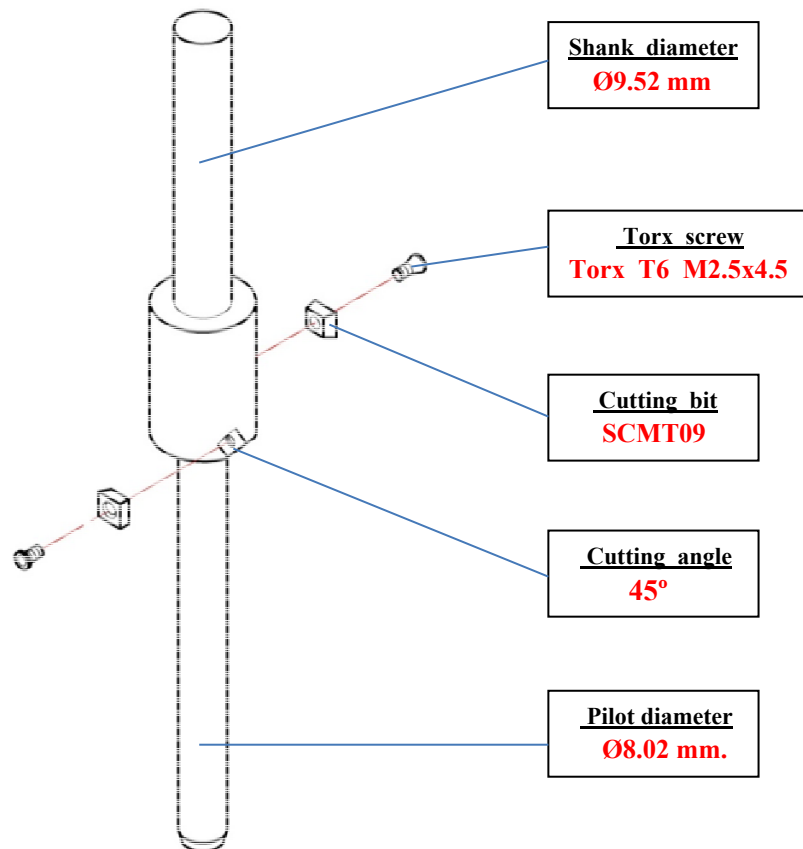
MERCEDES ACTROS
(EXHAUST BRAKE VALVE SEAT)

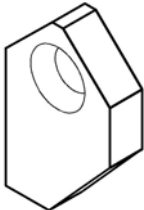
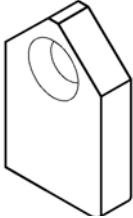
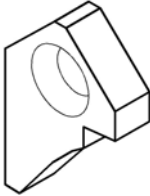

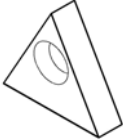
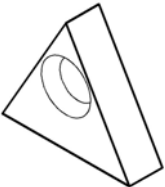
	A	STANDARD CUTTING BIT FOR ALMOST ANY CONVENTIONAL SINGLE ANGLE VALVE SEAT PROFILE
	A	COUNTERBORING CUTTING BIT FOR VALVE SEAT MACHINING
	B	STANDARD CUTTING BIT FOR SMALL 3 ANGLES VALVE SEAT PROFILE
	B	COUNTERBORING CUTTING BIT FOR SMALL VALVE SEAT MACHINING
	TCMT11	COUNTERBORING CUTTING BIT FOR STANDARD VALVE SEAT MACHINING
	TCMT16	COUNTERBORING AND SINGLE ANGLE CUTTING BIT FOR MEDIUM AND LARGE DIA. VALVE SEAT MACHINING

3 ANGLES CARBIDE CUTTING BITS - 45°

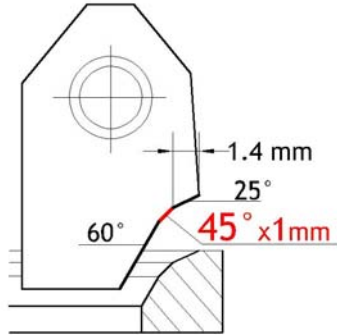

PRV410 A2

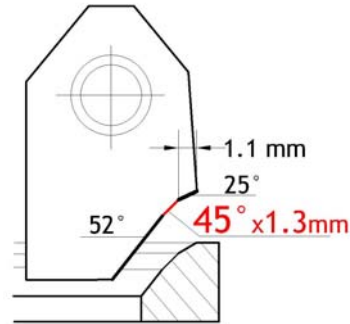

PRV413A3

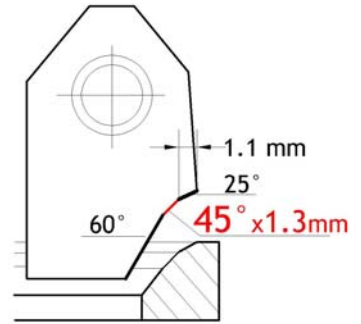

PRV413A4

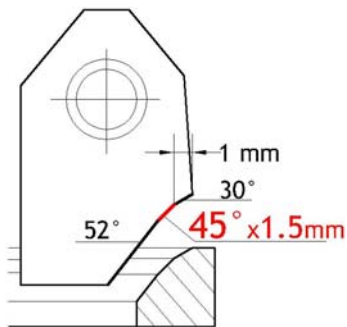

PRV415A1

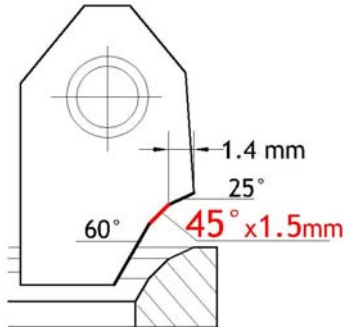

PRV415A2

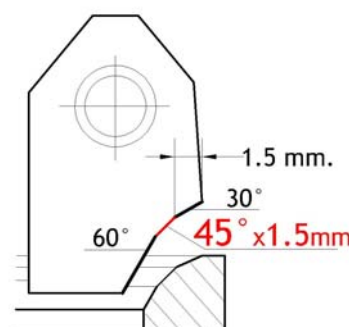

PRV415A3

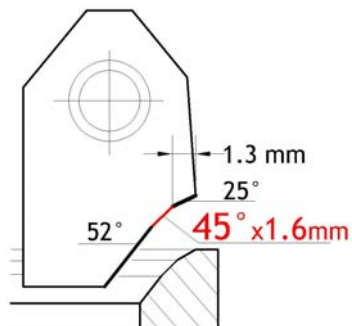

PRV416A3

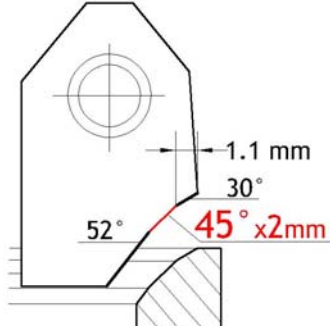

PRV 420A1

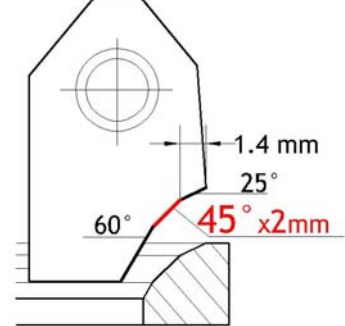

PRV420A2

3 ANGLES CARBIDE CUTTING BITS - 45°

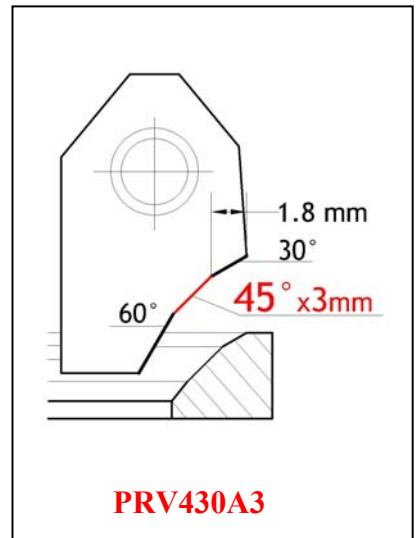
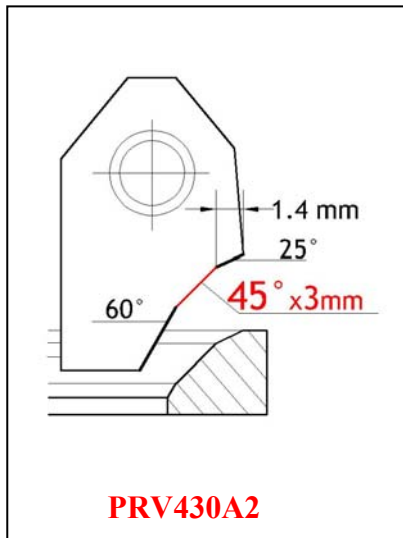
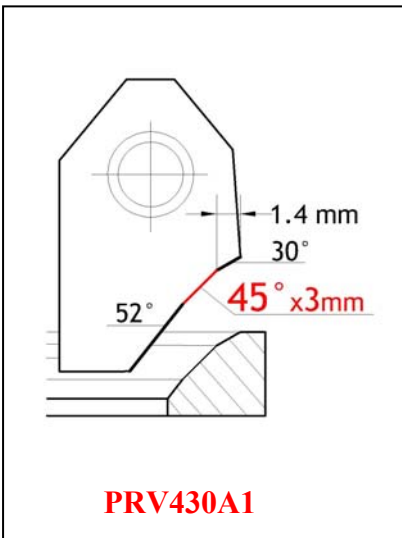
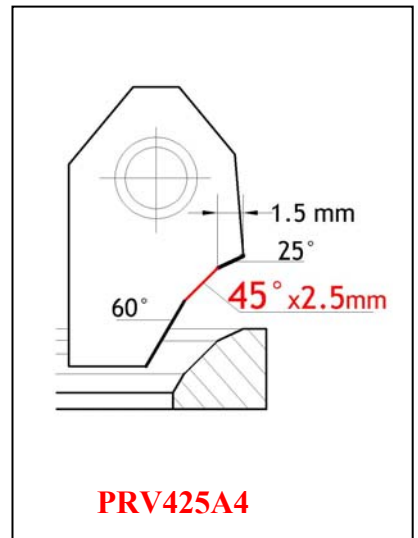
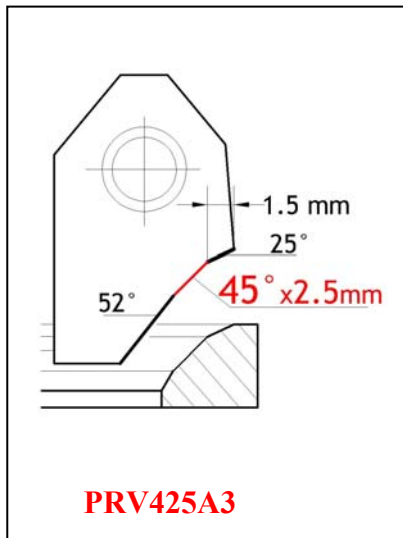
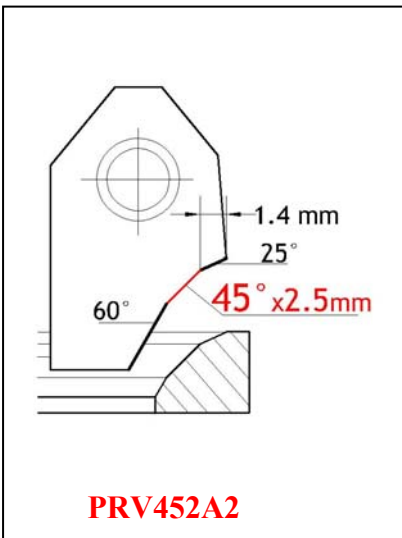
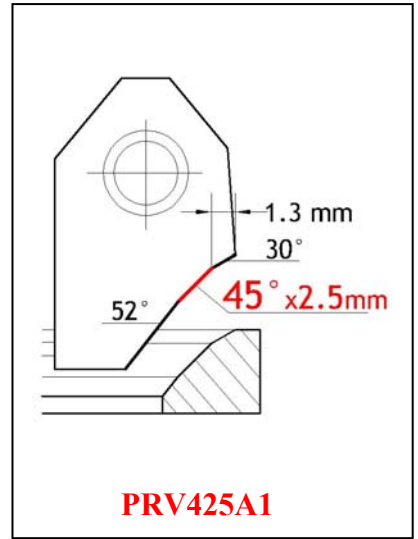
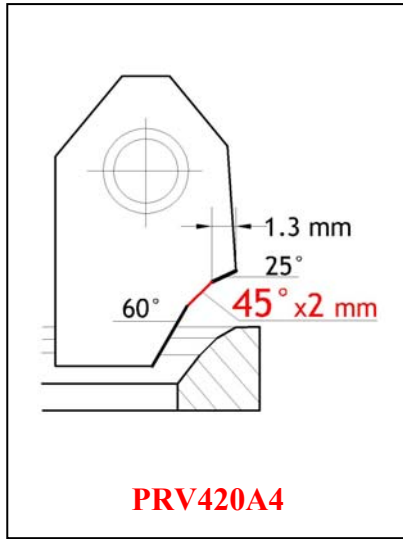
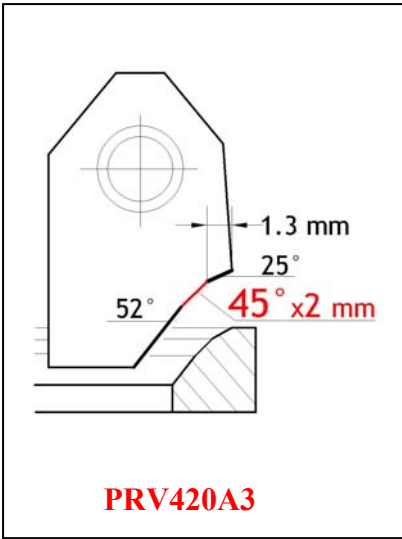

3 ANGLES CARBIDE CUTTING BITS - 30°

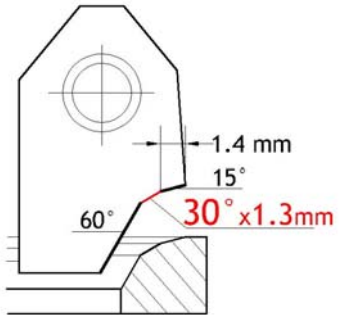

PRV313A2

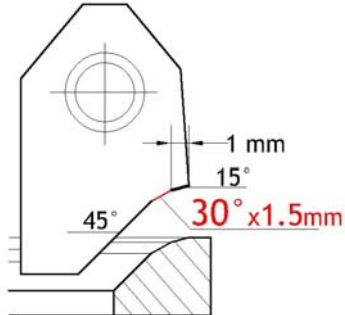

PRV315A1

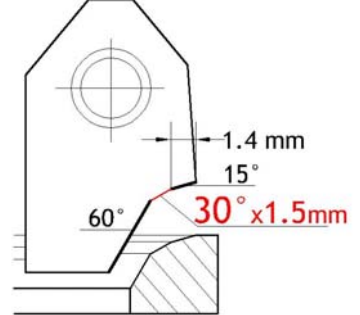

PRV315A2

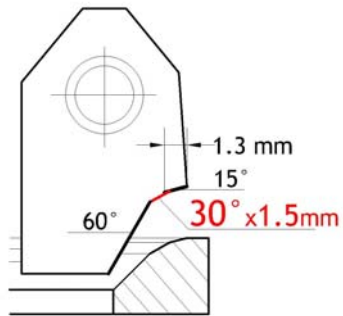

PRV315A3

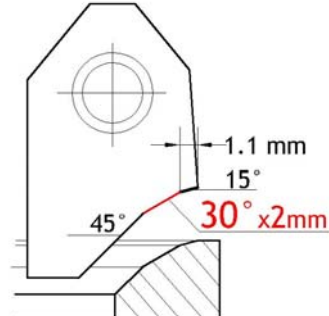

PRV320A1

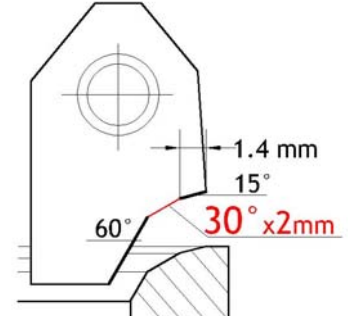

PRV320A2

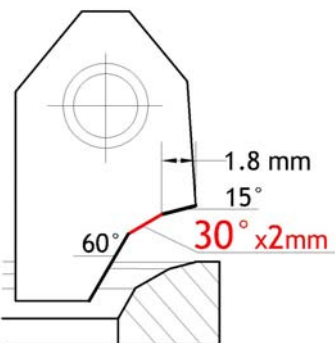

PRV320A3

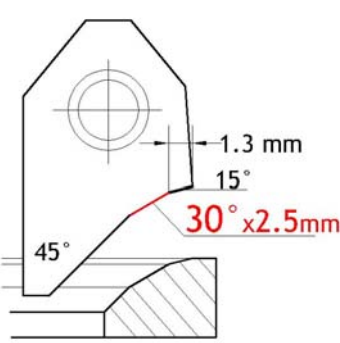

PRV325A1

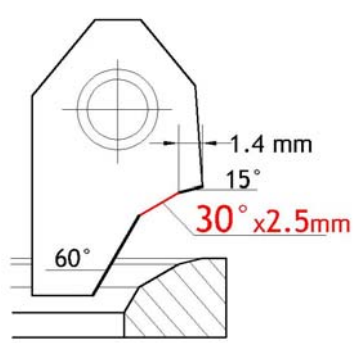

PRV325A2

3 ANGLES CARBIDE CUTTING BITS - 30°

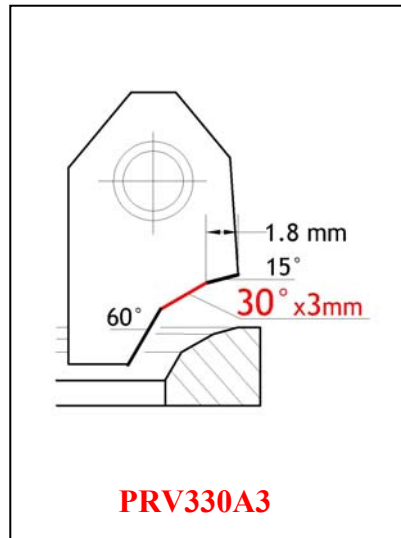
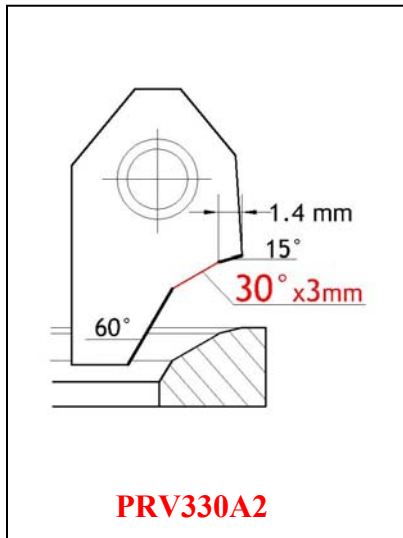



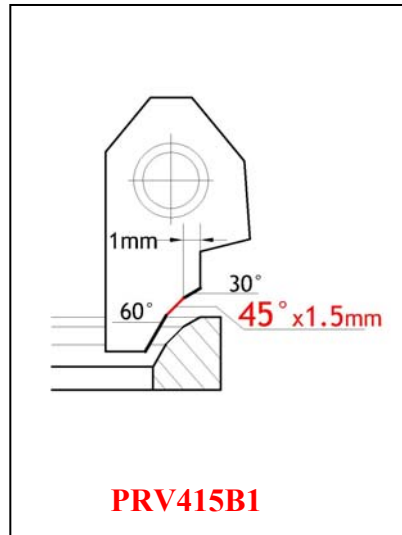
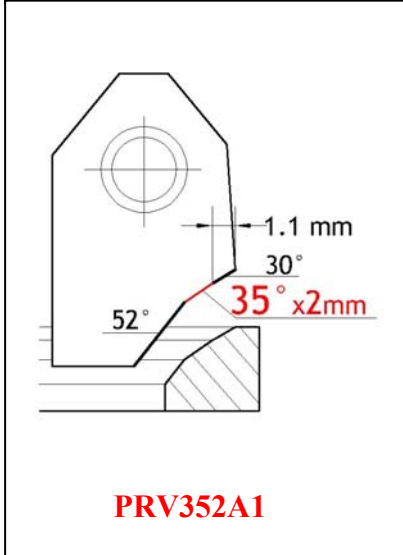
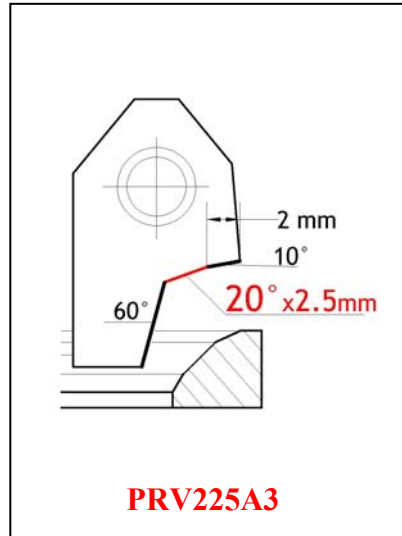
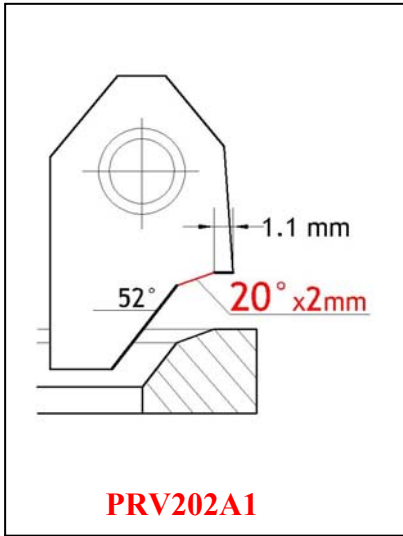

SPECIAL CARBIDE CUTTING BITS

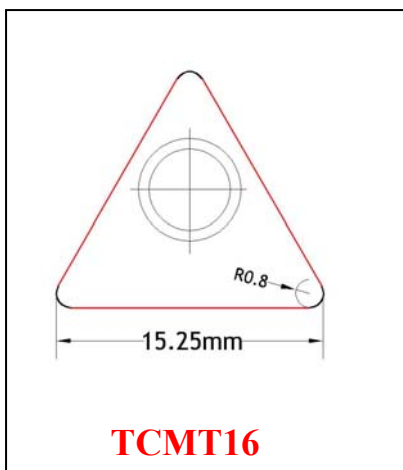
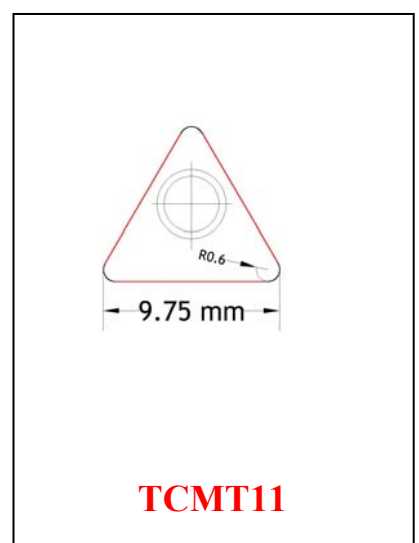
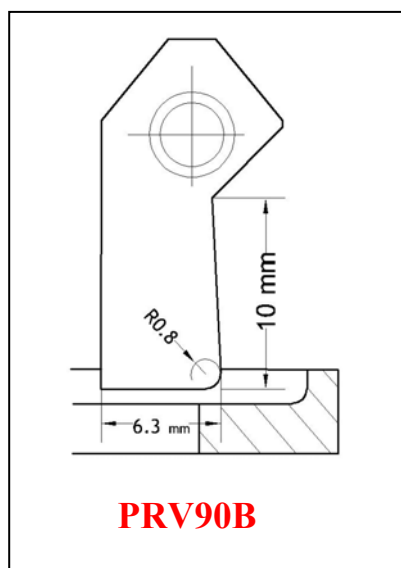
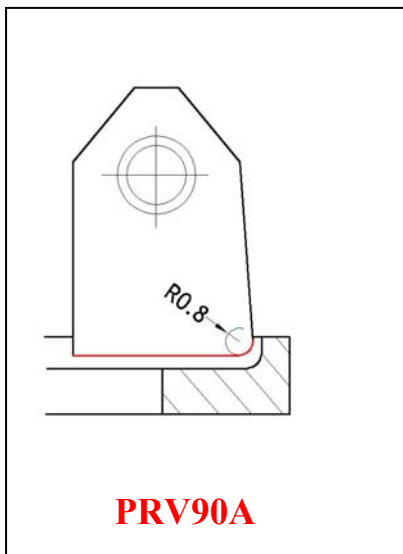
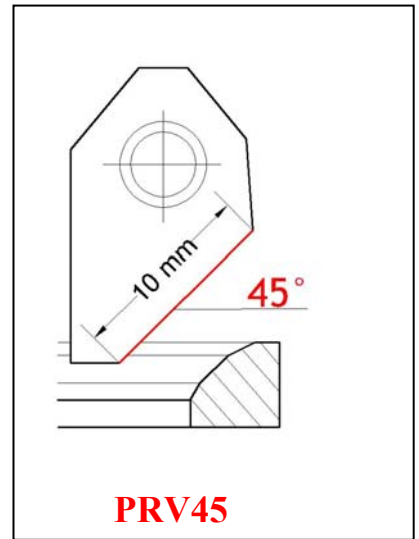
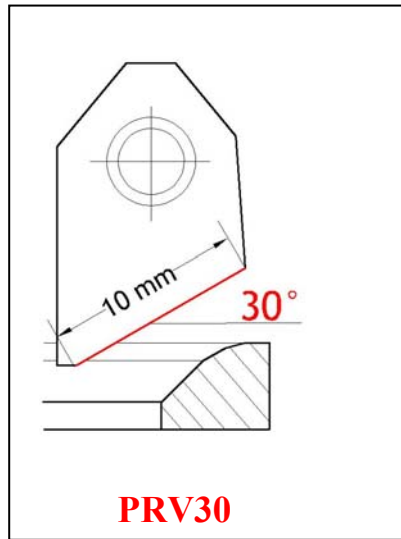
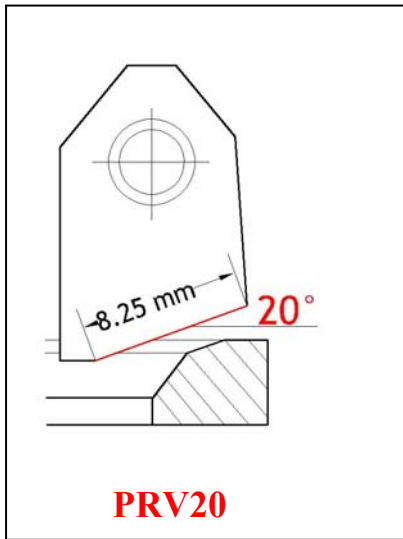

SINGLE ANGLE CARBIDE CUTTING BITS



	CP	CARBIDE PILOT FOR SMALL and MEDIUM DIA. GUIDE
	CPL	CARBIDE PILOT FOR LARGE DIA. GUIDE
	CPXL	CARBIDE PILOT FOR EXTRA LARGE- LONG DIA. GUIDE
	CPB	CARBIDE PILOT FOR BIG-LONG DIA. GUIDE

CP

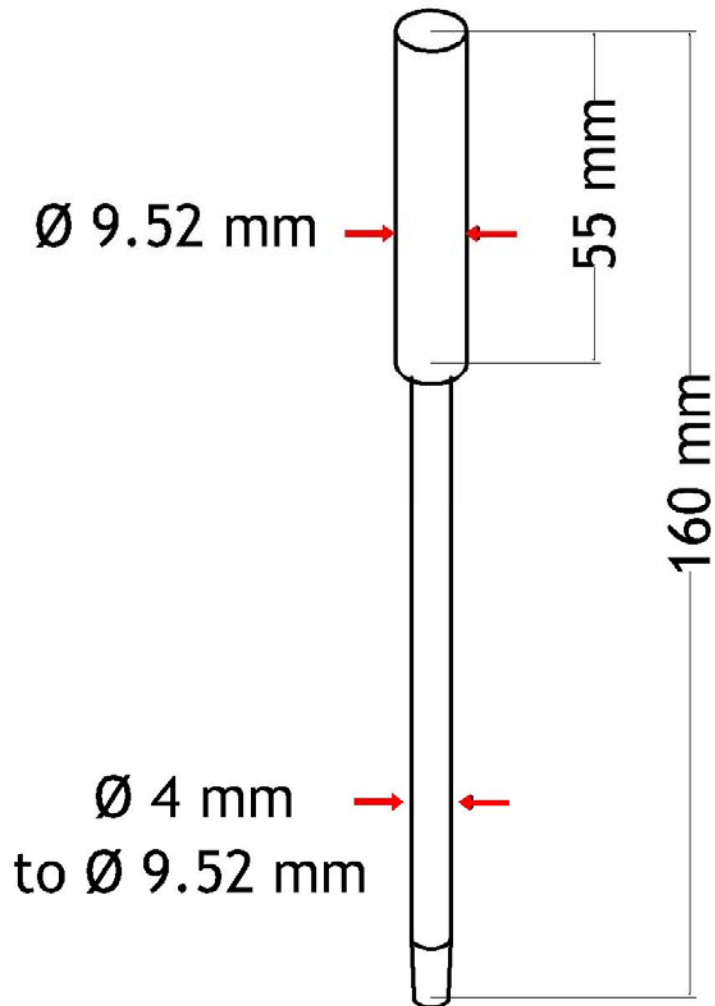

ONLY

TOOL HOLDER:

- SH-100
- SH-102
- SH-200
- SH-300
- SH-400

CPL

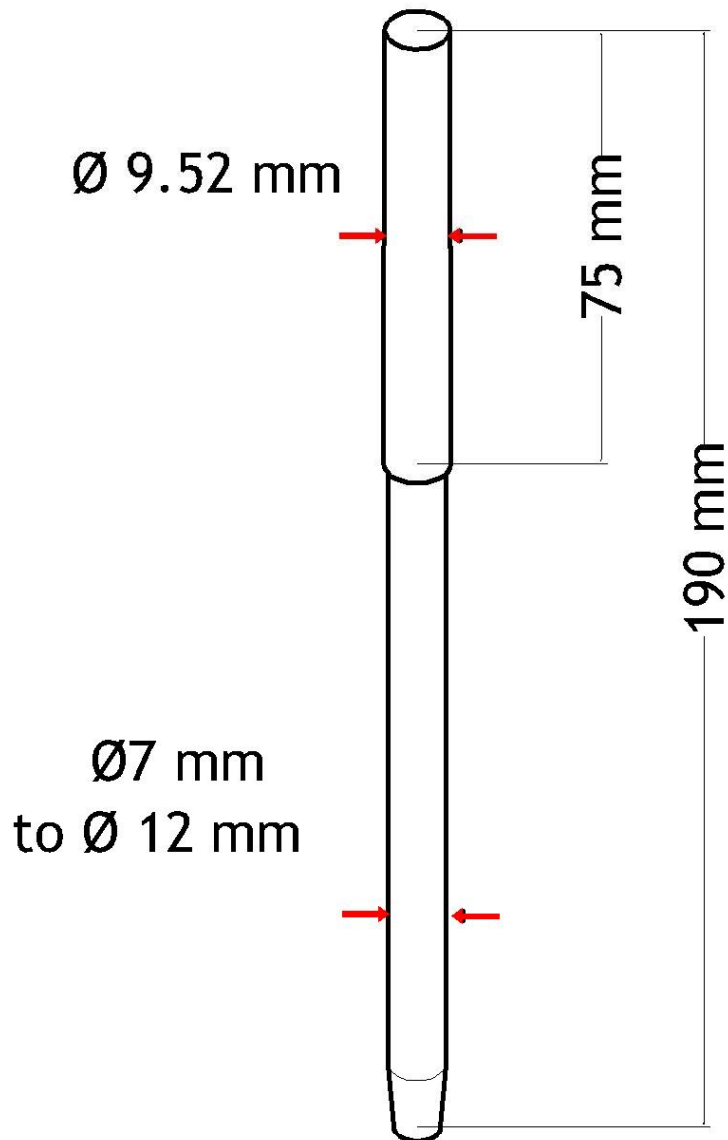

ONLY

TOOL HOLDER:

- SH-100
- SH-102
- SH-200
- SH-300
- SH-400

CPXL

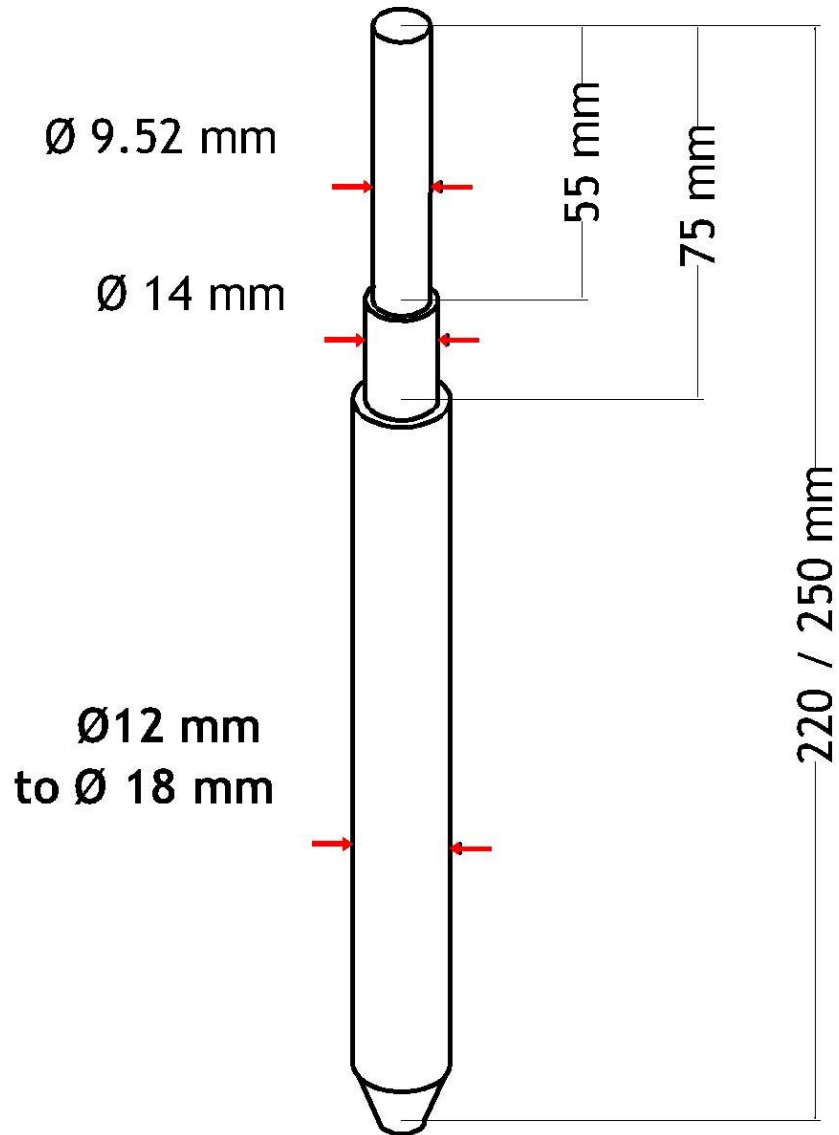

ONLY

TOOL HOLDER:

- SH-100
- SH-102
- SH-200
- SH-300
- SH-400

CARBIDE PILOTS

CPB

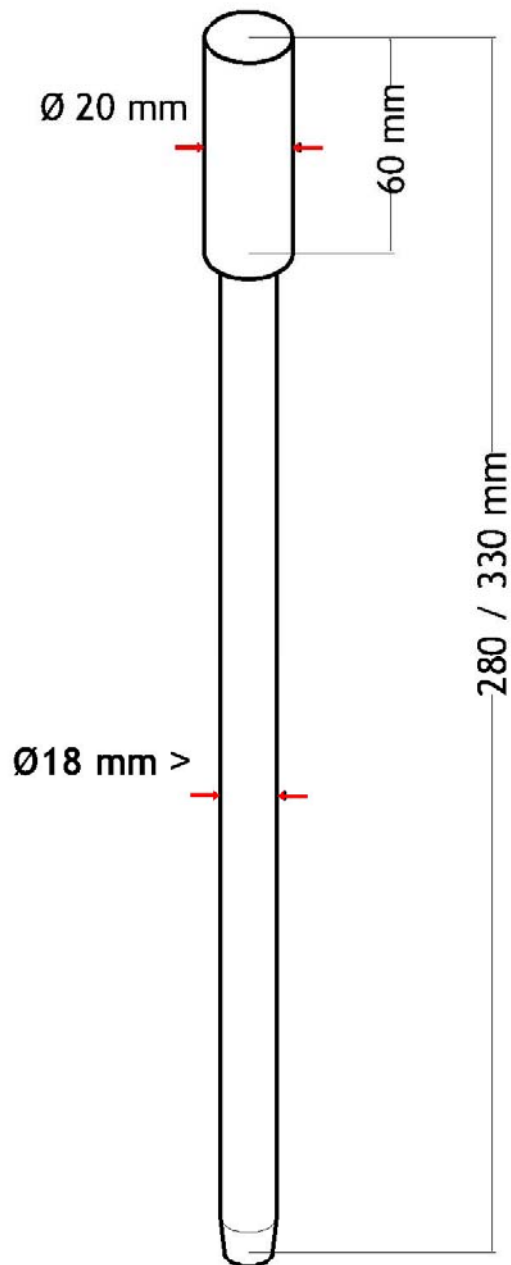

ONLY

TOOL HOLDER:
-SH-500



PROVALVE

İvedik Organize Sanayi Bölgesi 1548.Sokak No:21-23
06378 Yenimahalle / ANKARA – TURKEY
Tel : +90 312 395 39 65 / +90 312 395 39 66
Mobil : +90 507 923 89 03
Fax: +90 312 395 41 69



CLIO TECNO TRADE

Strada Preserasca 14 A/B
10024 MONCALIERI TO - ITALIA
telefono +39 011 629.0141
mobile +39 335 609.3414
mail info@cliotecnotrade.it

USER FRIENDLY AND HIGH EFFICIENCY MACHINES