

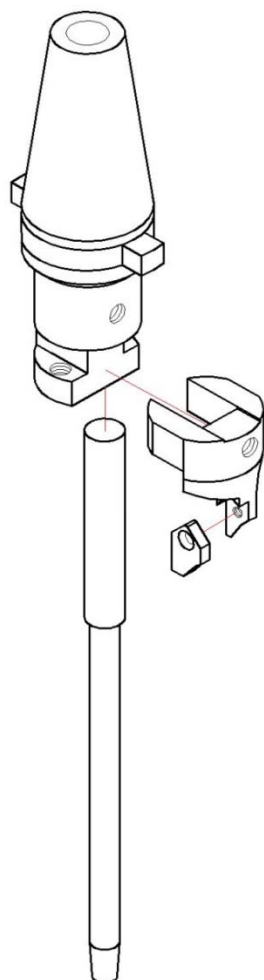

PRO VALVE

CATALOGO ATTREZZATURE



CONTENUTI

<u>MANDRINI STANDARD PER FRESATURA E RIPORTO SEDI.....</u>	1-6
-SH-100	1
-SH-102	2
-SH-200	3
-SH-300	4
-SH-400	5
-SH-500	6
<u>SPECIAL CUTTING SYSTEM TOOLING RANGE FOR SEATS MACHINING.....</u>	7-10
-SH-100,SH-102,SH-200 (Counterboring)	7
-SH-300 (Single angles)	8
-SH-400 (Single angles)	9
-SH-500 (Single ,angles)	10
<u>SPECIAL TOOL HOLDERS</u>	11-13
-DMH-2	11
-MAT-20	12
-MAC-45	13
<u>UTENSILI IN CARBURO DI TUNGSTENO.....</u>	14-19
-UTENSILI MULTIANGOLO A 45°	14 - 15
-UTENSILI MULTIANGOLO A 30°	16 - 17
-UTENSILI MULTINANGOLO SPECIALI	18
-UTENSILI MONOANGOLO.....	19
<u>CARBIDE PILOTS</u>	20-38
- CP CARBIDE PILOT	20
- CPL CARBIDE PILOT	21
- CPXL CARBIDE PILOT	22
- CPB CARBIDE PILOT	23

ATTREZZATURE STANDARD PER LAVORAZIONE SEDI

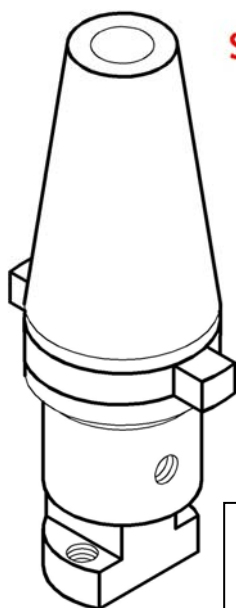

SH-100

Fork width : **12mm**
 Fork height: **9.5mm**
 Pilot hole : **Ø9.52mm**

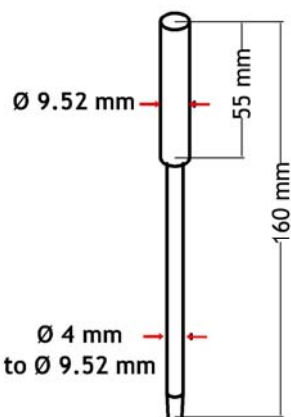

CP

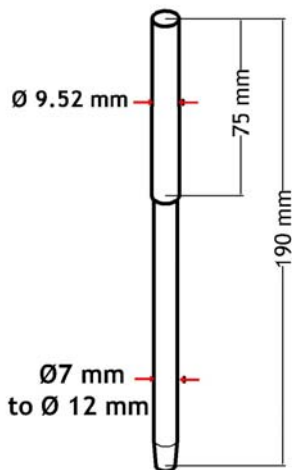

CPL

SH-0L

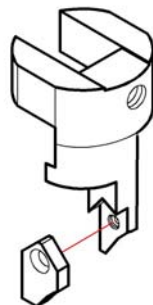

Long type

Campo di lavoro sedi
Ø16 – Ø30 mm

SH-0



Campo di lavoro sedi
Ø16 – Ø30 mm

SH-1

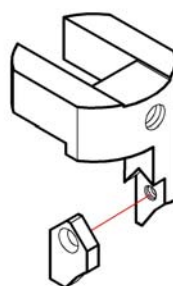

Campo di lavoro sedi
Ø28 – Ø42 mm

SH-2

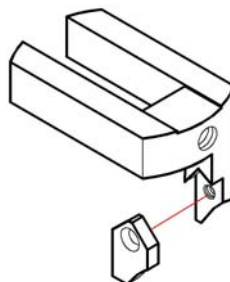

Campo di lavoro sedi
Ø40 – Ø58 mm

ATTREZZATURE STANDARD PER LAVORAZIONE SEDI

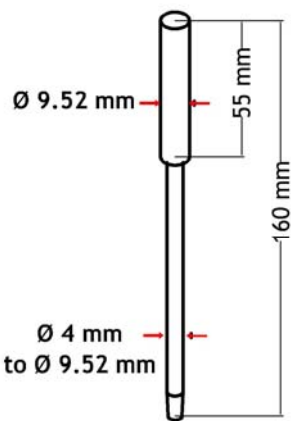
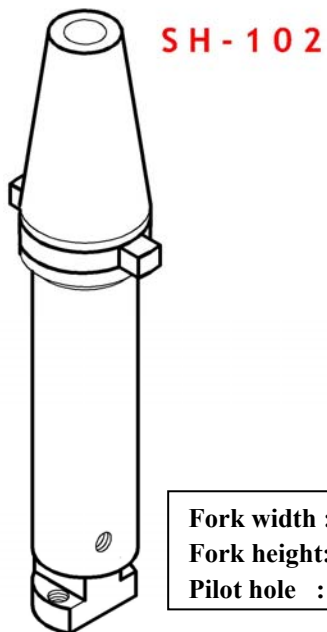

CP

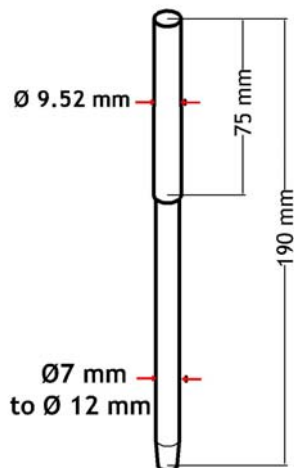

CPL

SH-0L

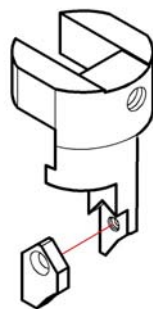

Campo di lavoro sedi
Ø16 – Ø30 mm

SH-0



SH-1

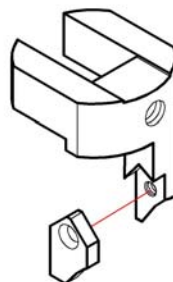

SH-2

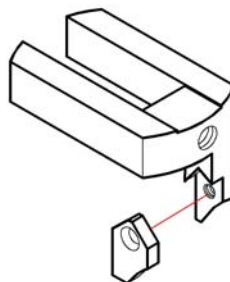

ATTREZZATURE STANDARD PER LAVORAZIONE SEDI

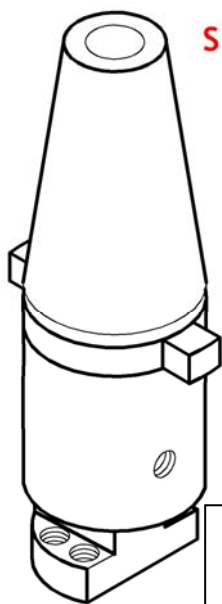

SH-200

Fork width : 12mm
Fork height: 9.5mm
Pilot hole : Ø9.52mm

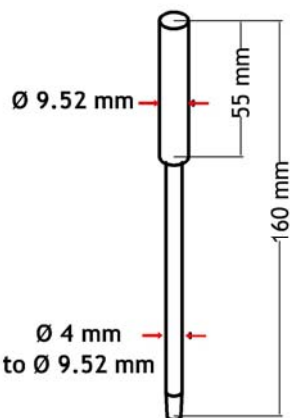

CP

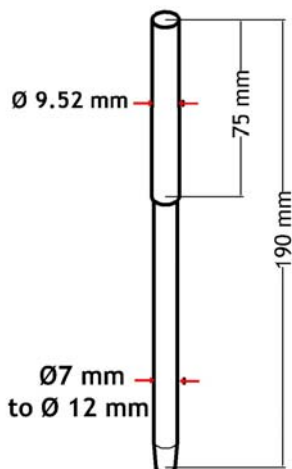

CPL

SH-0L

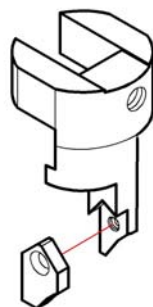

Long type

Campo di lavoro sedi
Ø16 – Ø30 mm

SH-0

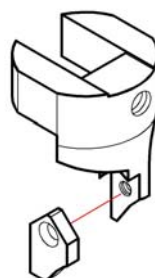

Campo di lavoro sedi
Ø16 – Ø30 mm

SH-1

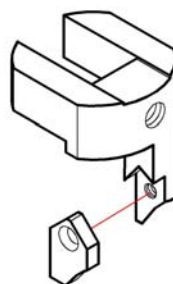

Campo di lavoro sedi
Ø28 – Ø42 mm

SH-2

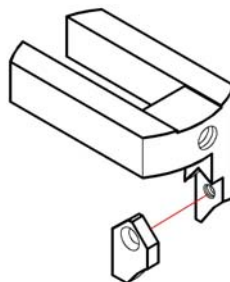

Campo di lavoro sedi
Ø40 – Ø58 mm

ATTREZZATURE STANDARD PER LAVORAZIONE SEDI

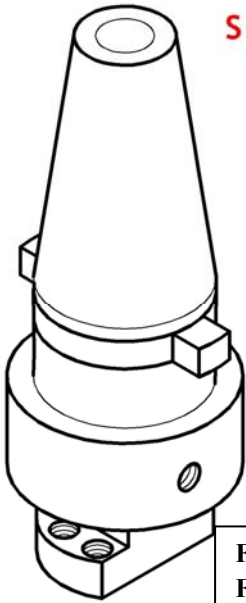

SH-300

Fork width : **14mm**
Fork height: **11mm**
Pilot hole : **Ø9.52mm**

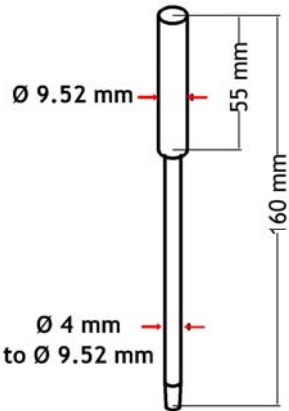

CP

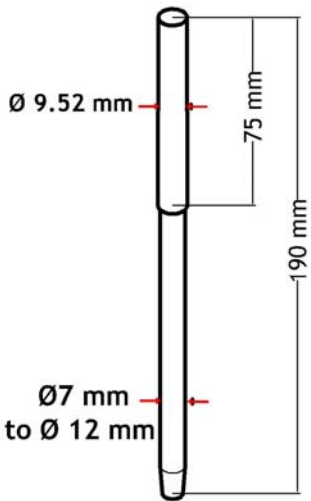

CPL

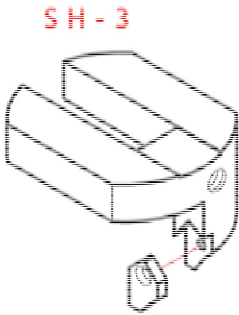

SH-3

Campo di lavoro sedi
Ø40 - Ø70 mm

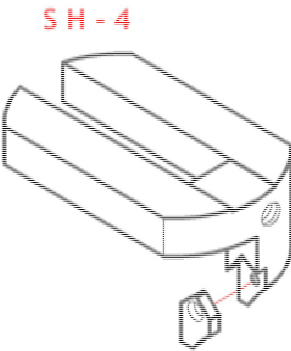

SH-4

Campo di lavoro sedi
Ø45 - Ø90 mm

ATTREZZATURE STANDARD PER LAVORAZIONE SEDI

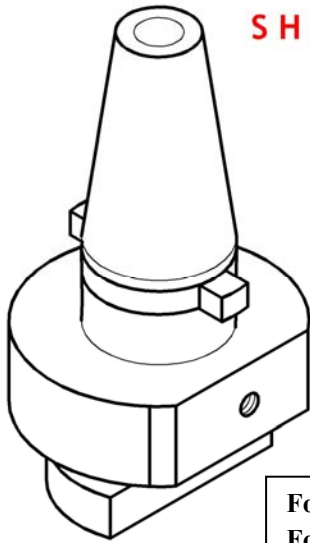

SH-400

Fork width : **14mm**
Fork height: **11mm**
Pilot hole : **Ø9.52mm**

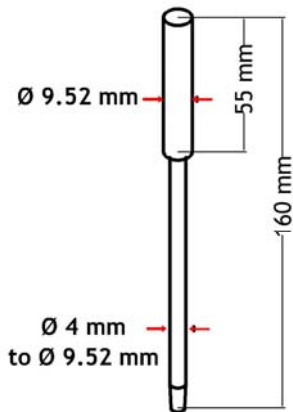

CP

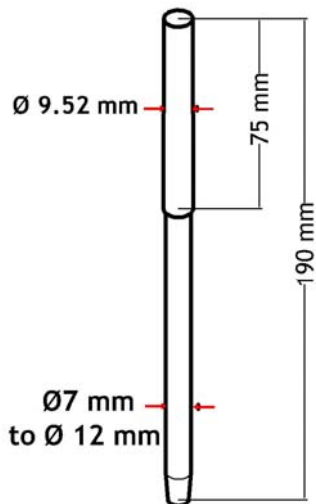

CPL

SH-3

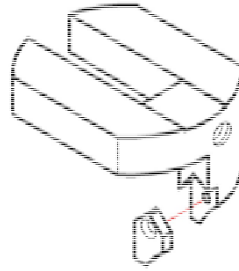

Campo di lavoro sedi
Ø45 - Ø75 mm

SH-4

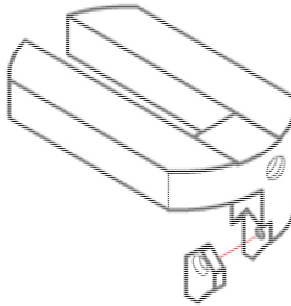

Campo di lavoro sedi
Ø50 - Ø100 mm

ATTREZZATURE STANDARD PER LAVORAZIONE SEDI

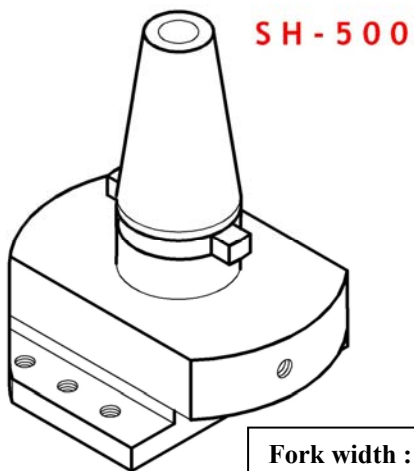

Fork width : **25mm**
Fork height: **12mm**
Pilot hole : **Ø20mm**

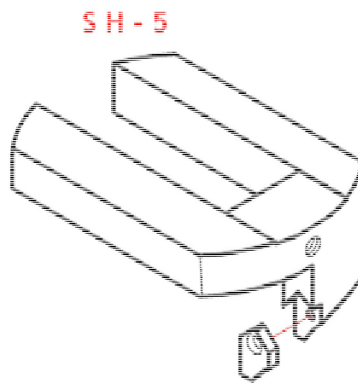
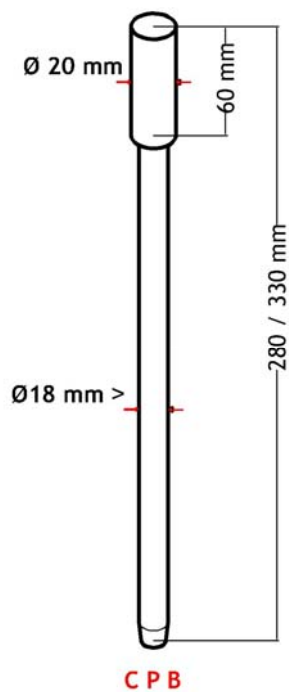

Campo di lavoro sedi
Ø70 - Ø120 mm

ATTREZZATURE SPECIALI PER LAVORAZIONE SEDI

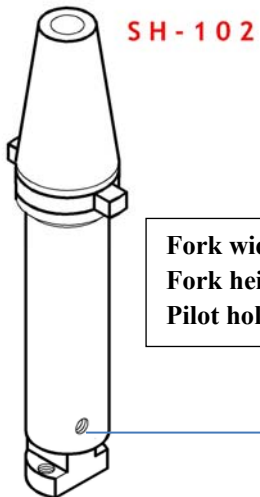
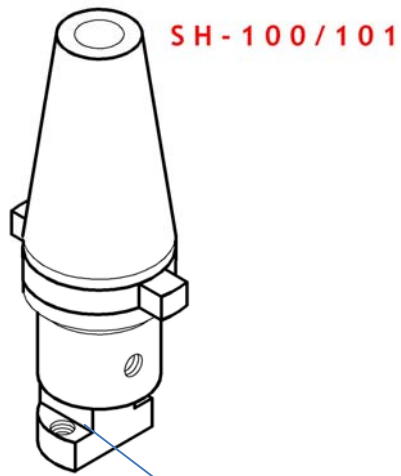

Fork width : 14mm
Fork height: 11mm
Pilot hole : Ø9.52mm

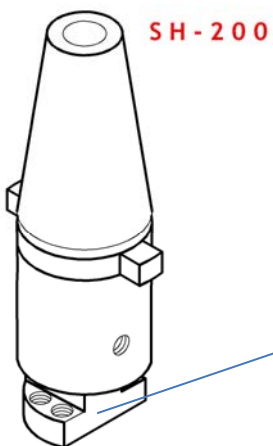

SH-190

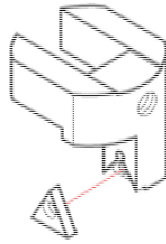

TCMT-14



SH-290

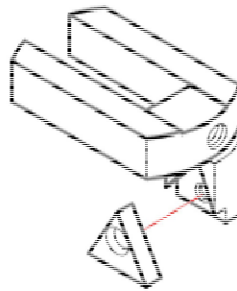

TCMT-16



ATTREZZATURE SPECIALI PER LAVORAZIONE SEDI

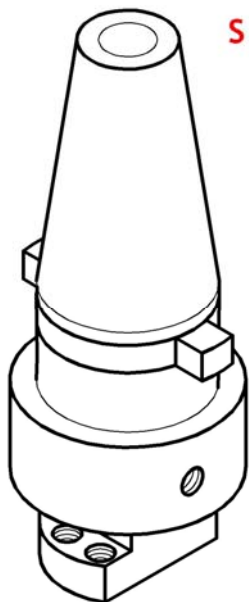

SH-300

Fork width : 14mm
Fork height: 11mm
Pilot hole : Ø9.52mm

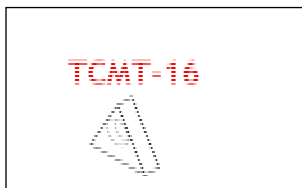

TCMT-16

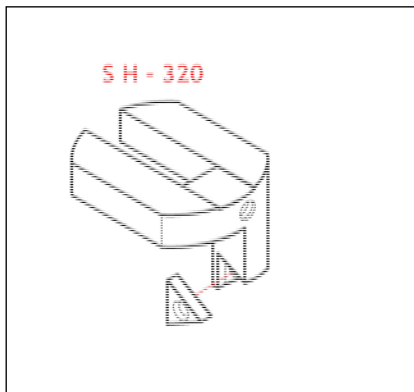

SH-320

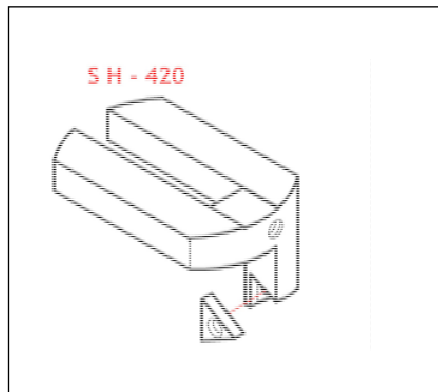

SH-420

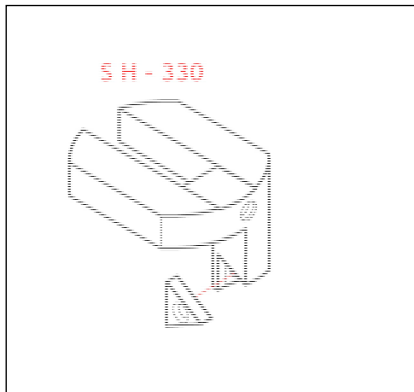

SH-330

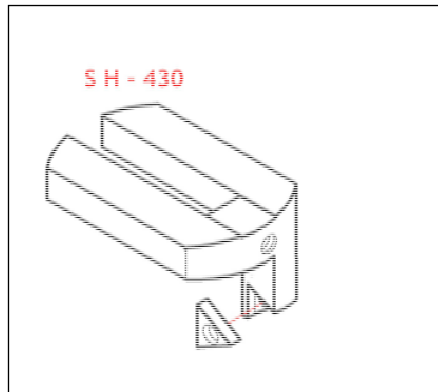

SH-430

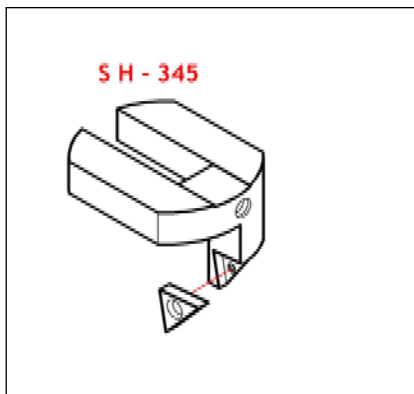

SH-345

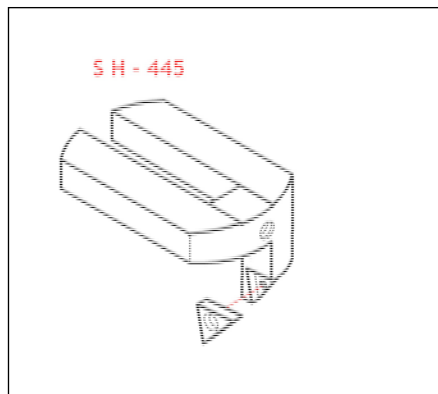

SH-445

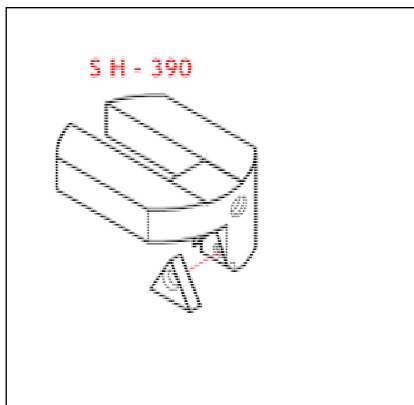

SH-390

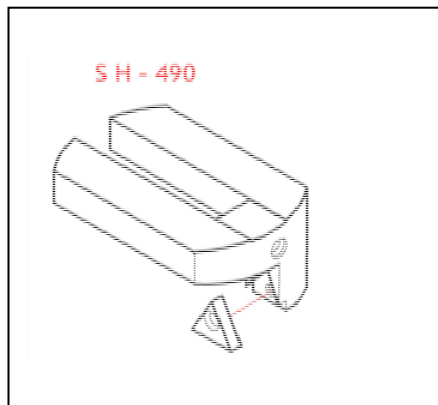

SH-490

ATTREZZATURE SPECIALI PER LAVORAZIONE SEDI

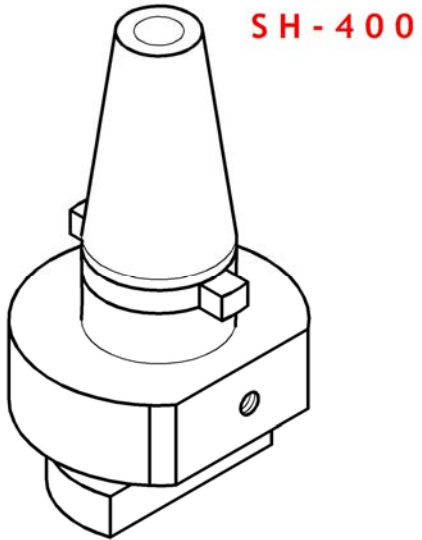

Fork width : 14mm
Fork height: 11mm
Pilot hole : Ø9.52mm

TCMT-16



SH - 320

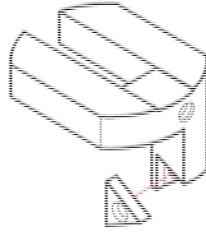

SH - 420

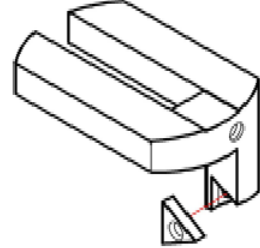

SH - 330

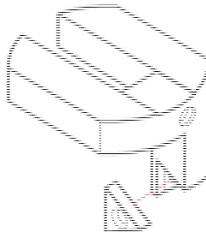

SH - 430

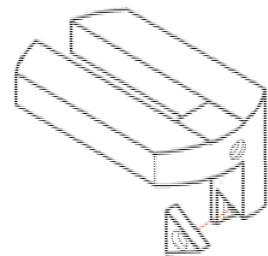

SH - 345

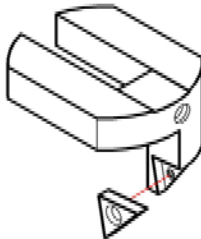

SH - 445

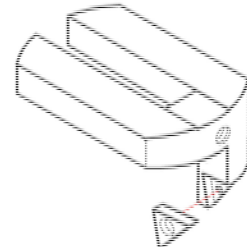

SH - 390

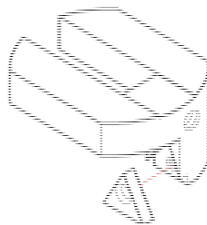

SH - 490

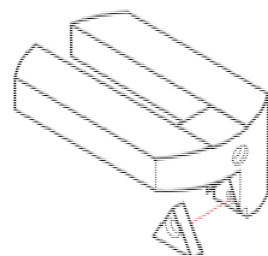

ATTREZZATURE SPECIALI PER LAVORAZIONE SEDI

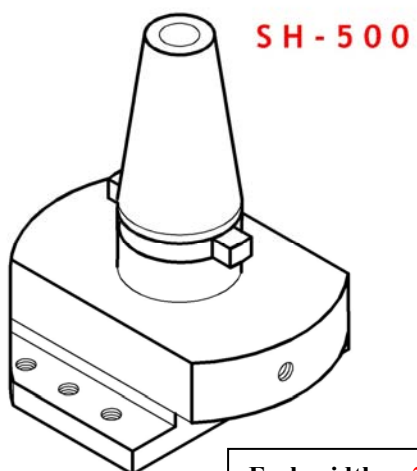

Fork width : 25mm
Fork height: 12mm
Pilot hole : Ø20mm

TCMT-16



SH - 520

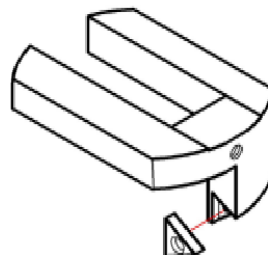

SH - 530

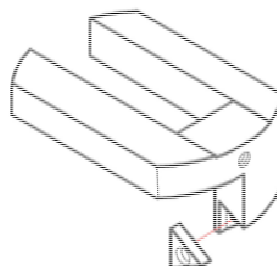

SH - 545

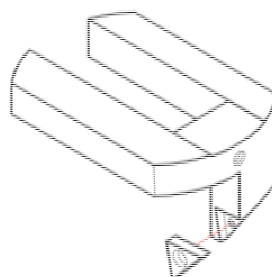

SH - 590

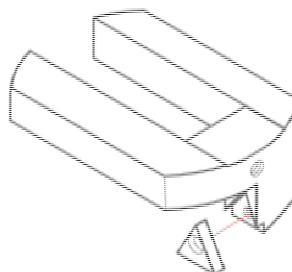

MANDRINI SPECIALI

DMH-2

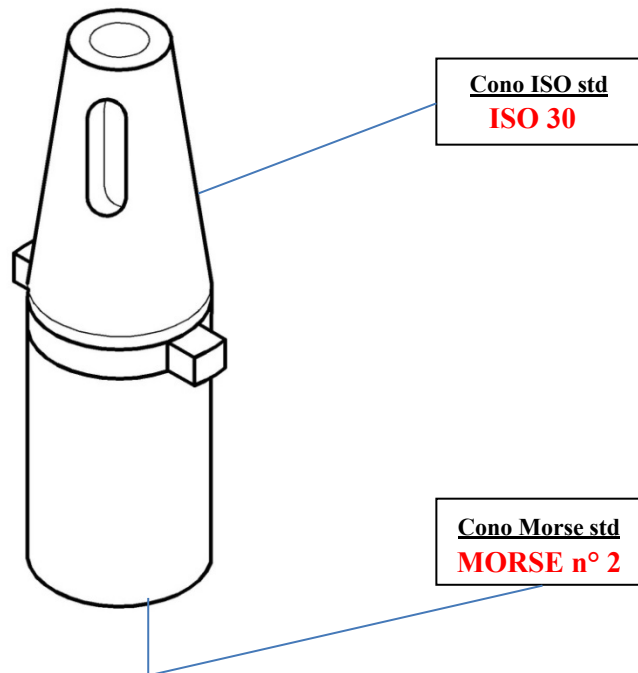

MANDRINO AUTOCENTRANTE DI PRECISIONE

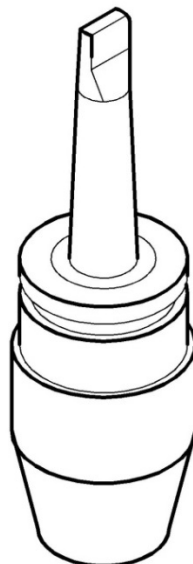

MANDRINI SPECIALI

MAT-20

MERCEDES ATEGO AXOR
(SEDE VALVOLA FRENO)

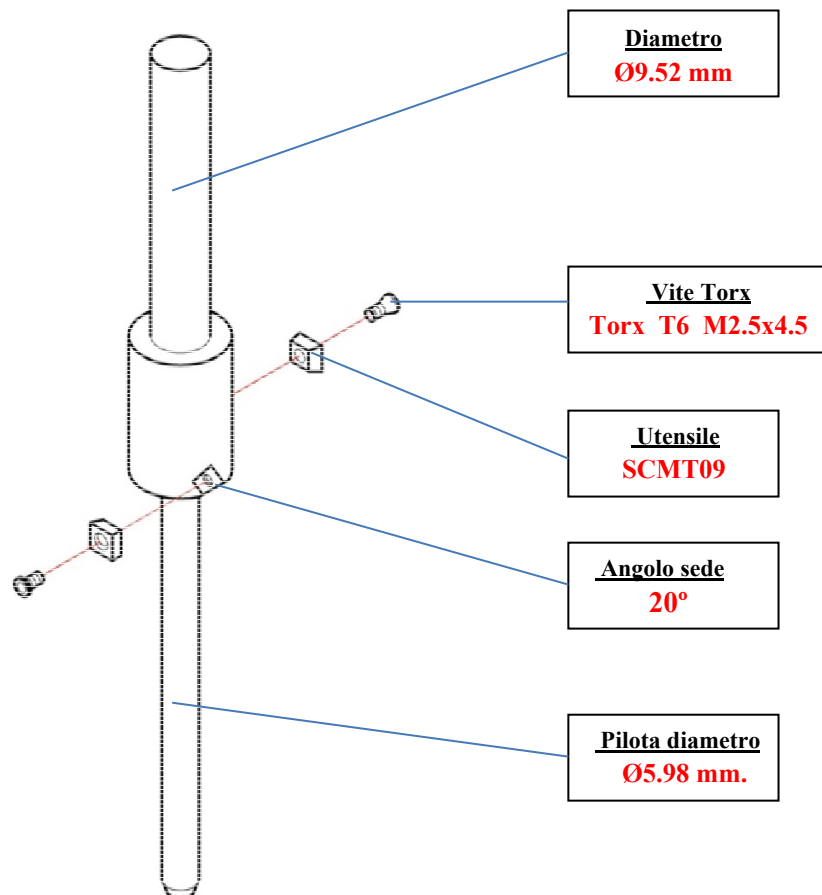



MANDRINI SPECIALI

MAC-45

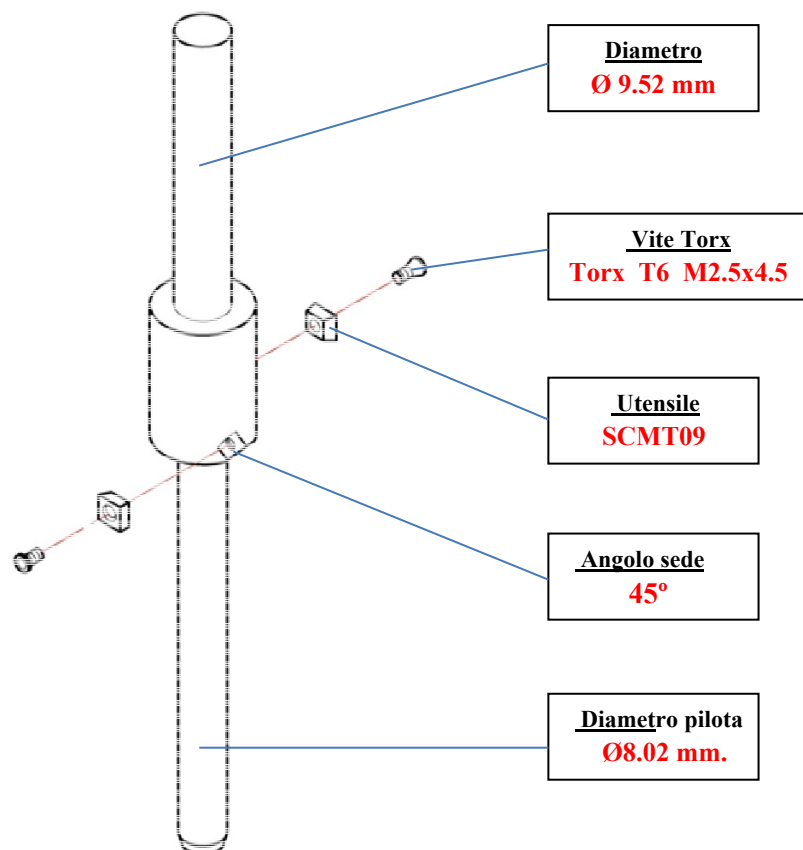
MERCEDES ACTROS
(SEDE VALVOLA FRENO)

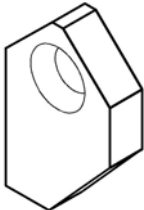
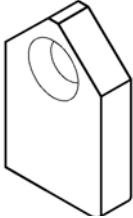
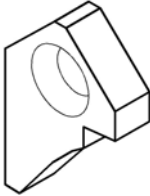

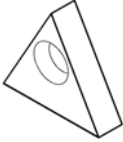
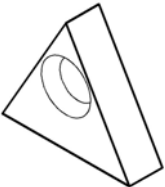
	A	STANDARD CUTTING BIT FOR ALMOST ANY CONVENTIONAL SINGLE ANGLE VALVE SEAT PROFILE
	A	COUNTERBORING CUTTING BIT FOR VALVE SEAT MACHINING
	B	STANDARD CUTTING BIT FOR SMALL 3 ANGLES VALVE SEAT PROFILE
	B	COUNTERBORING CUTTING BIT FOR SMALL VALVE SEAT MACHINING
	TCMT11	COUNTERBORING CUTTING BIT FOR STANDARD VALVE SEAT MACHINING
	TCMT16	COUNTERBORING AND SINGLE ANGLE CUTTING BIT FOR MEDIUM AND LARGE DIA. VALVE SEAT MACHINING

3 ANGLES CARBIDE CUTTING BITS - 45°

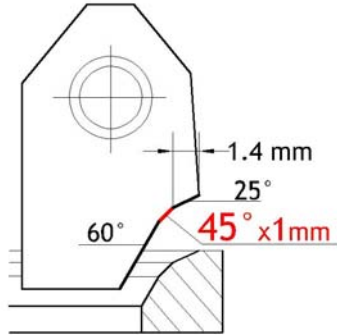

PRV410 A2

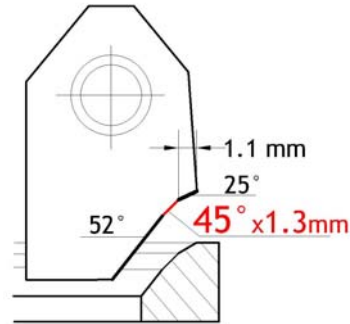

PRV413A3

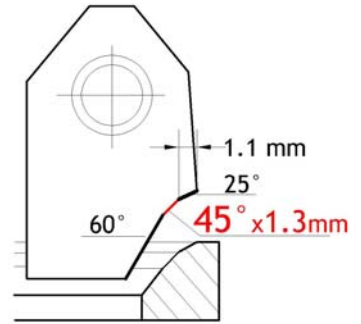

PRV413A4

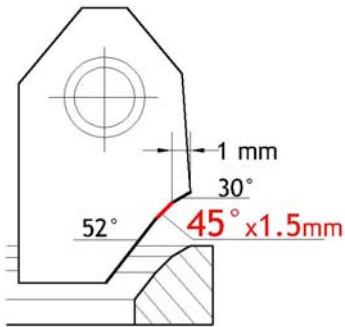

PRV415A1

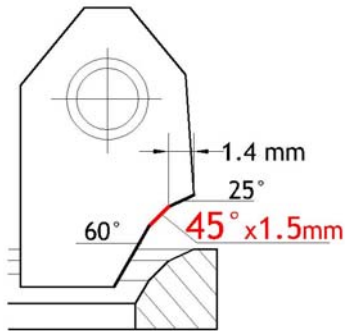

PRV415A2

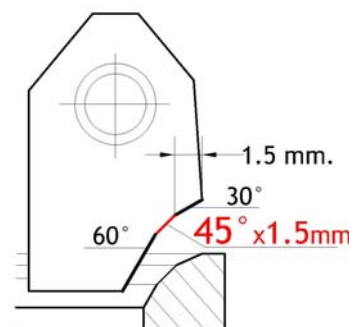

PRV415A3

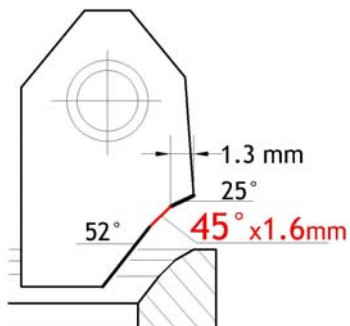

PRV416A3

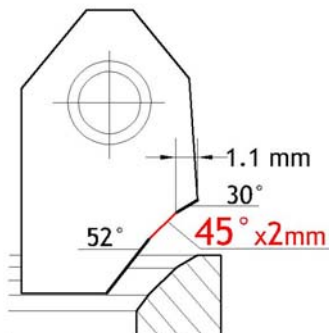

PRV 420A1

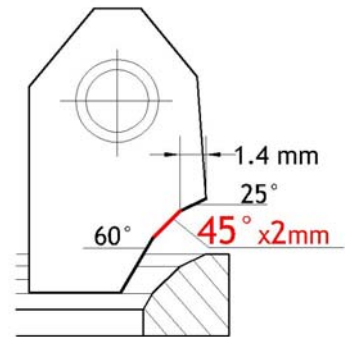

PRV420A2

3 ANGLES CARBIDE CUTTING BITS - 45°

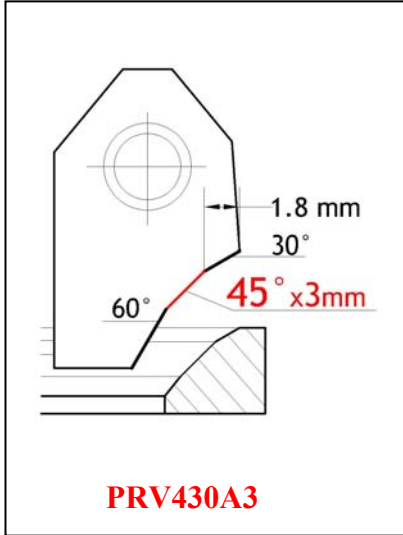
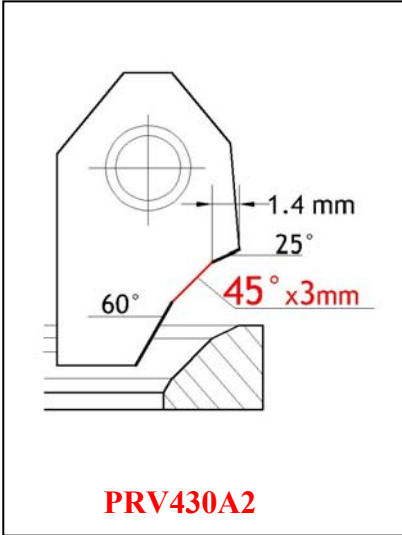
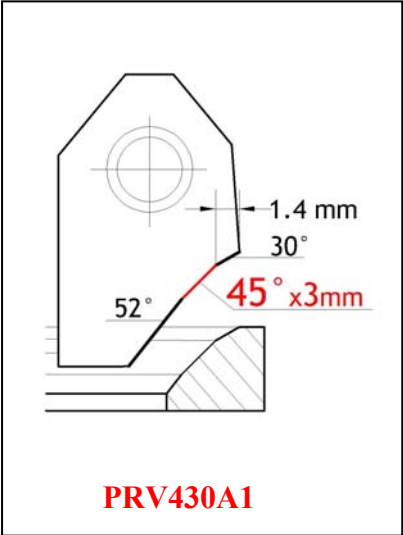
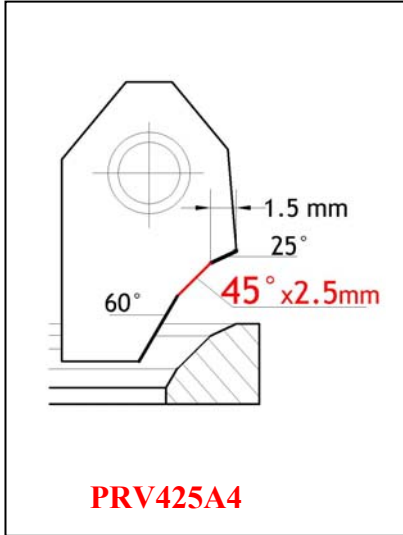
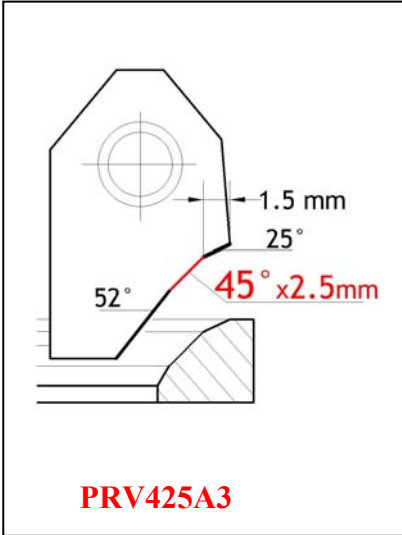
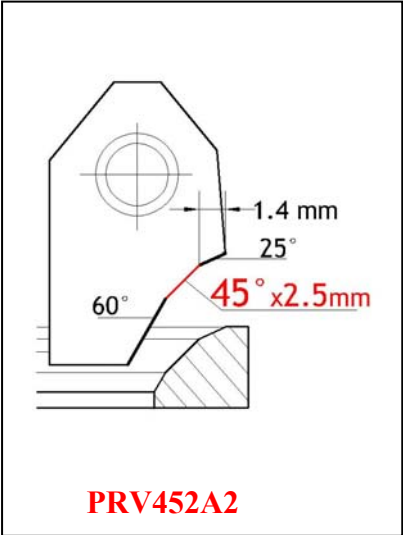
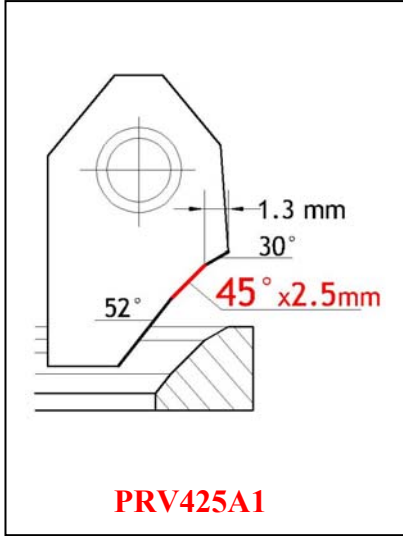
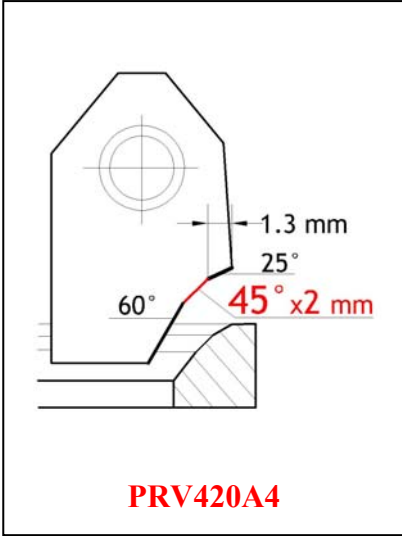
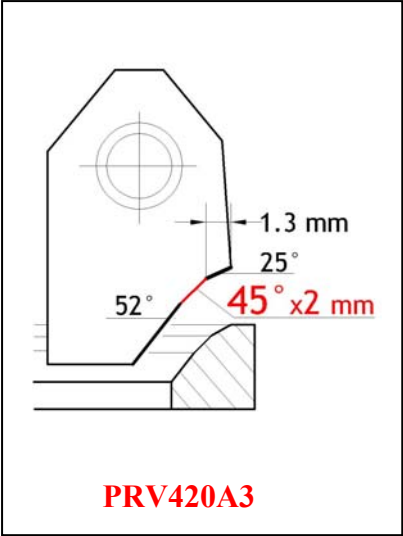

3 ANGLES CARBIDE CUTTING BITS - 30°

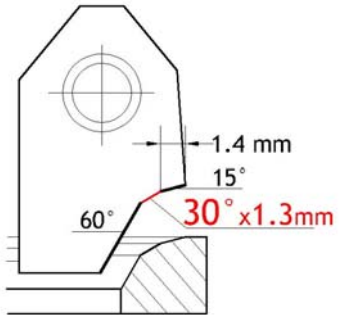

PRV313A2

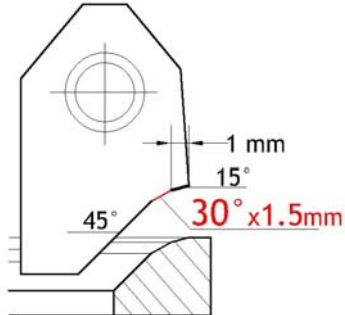

PRV315A1

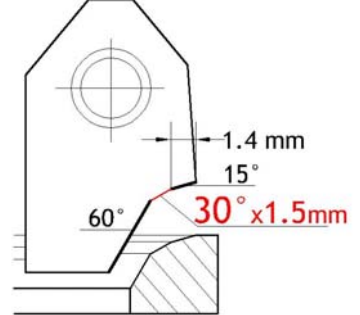

PRV315A2

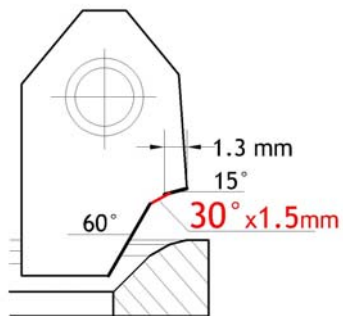

PRV315A3

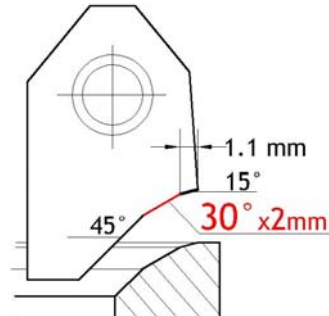

PRV320A1

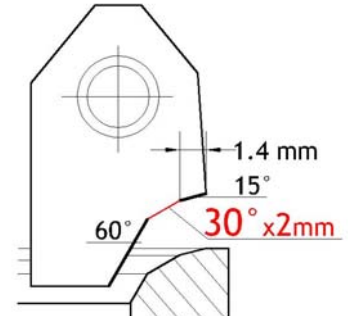

PRV320A2

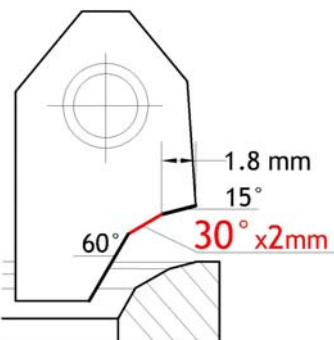

PRV320A3

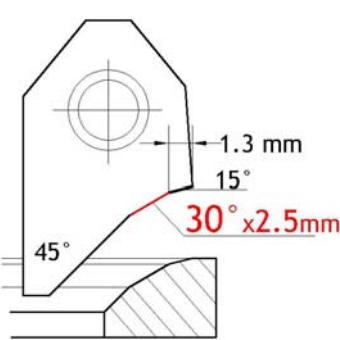

PRV325A1

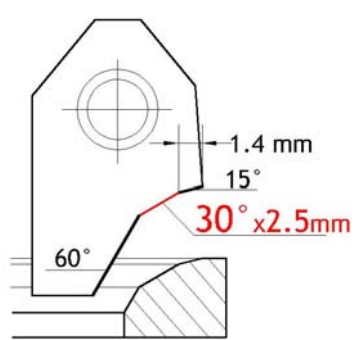

PRV325A2

3 ANGLES CARBIDE CUTTING BITS - 30°

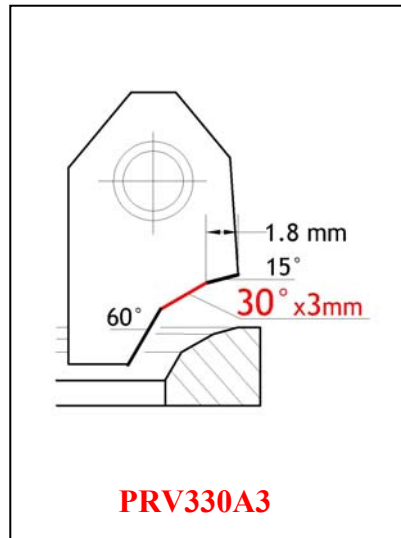
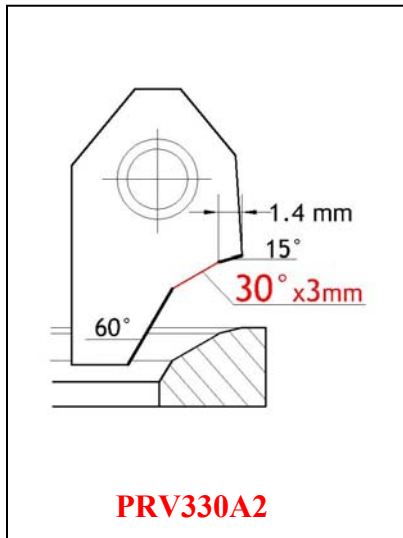



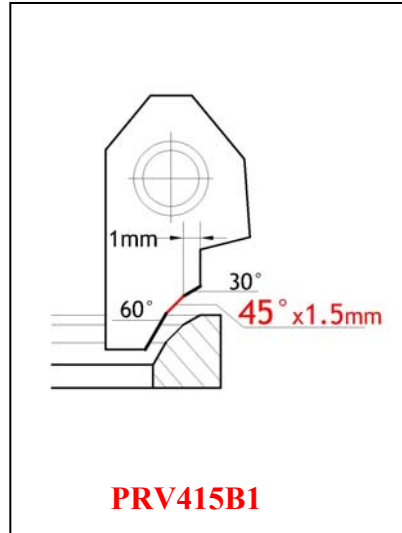
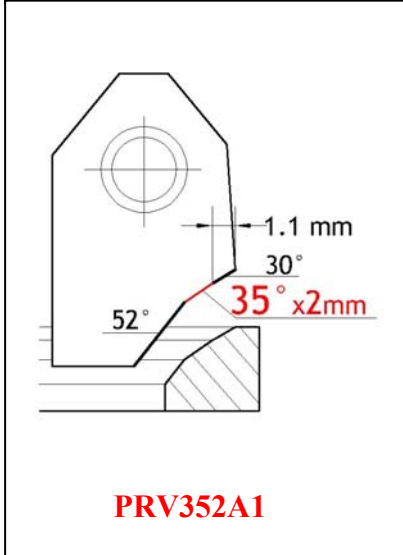
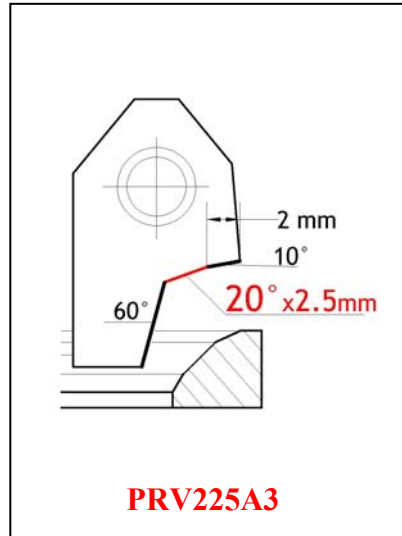
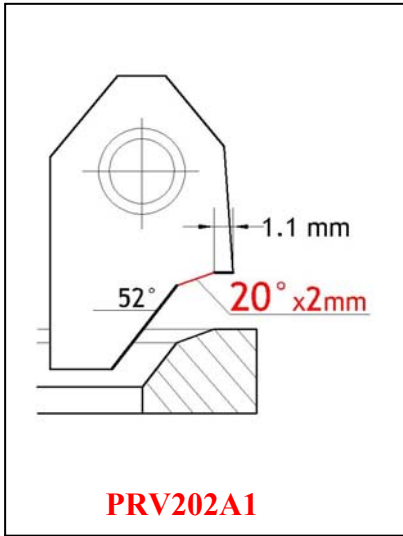

SPECIAL CARBIDE CUTTING BITS

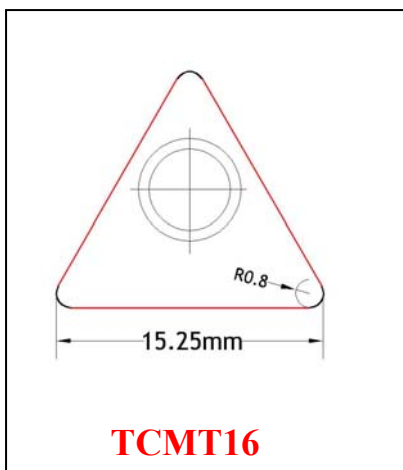
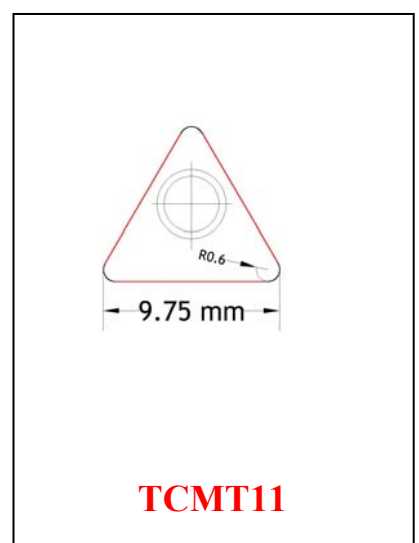
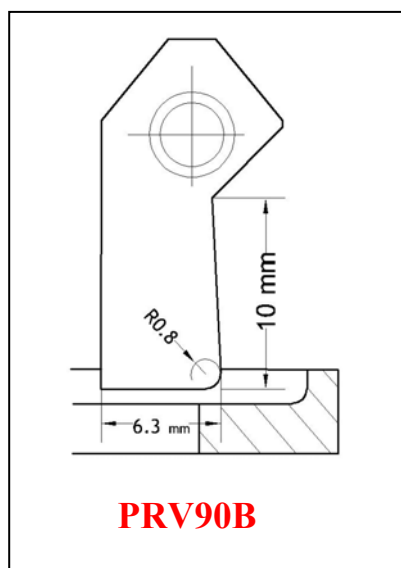
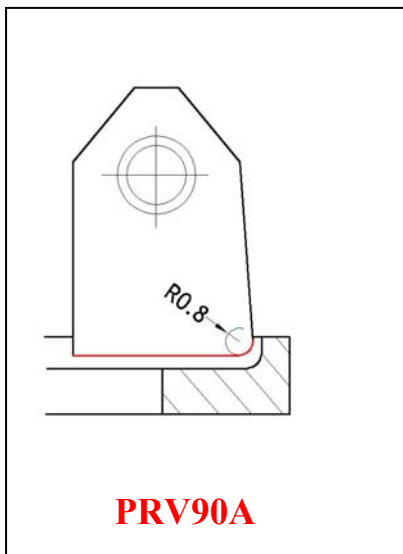
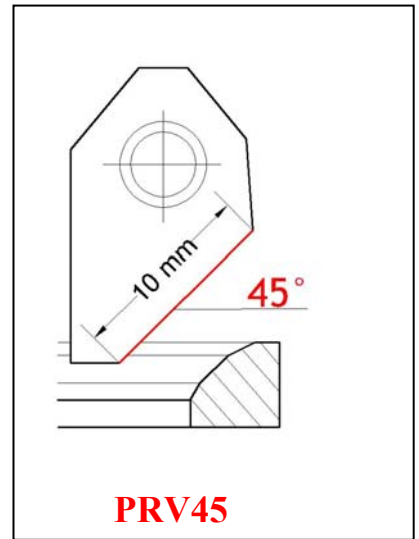
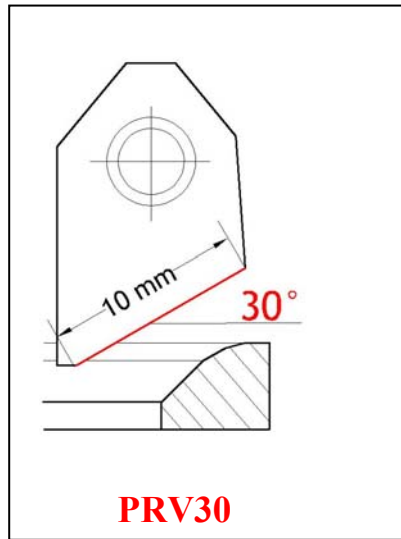
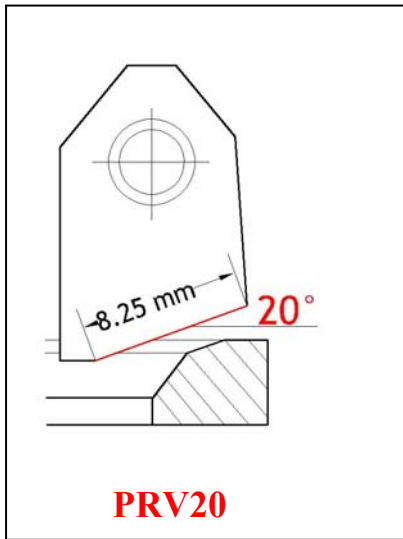

SINGLE ANGLE CARBIDE CUTTING BITS



	CP	CARBIDE PILOT FOR SMALL and MEDIUM DIA. GUIDE
	CPL	CARBIDE PILOT FOR LARGE DIA. GUIDE
	CPXL	CARBIDE PILOT FOR EXTRA LARGE- LONG DIA. GUIDE
	CPB	CARBIDE PILOT FOR BIG-LONG DIA. GUIDE

CP

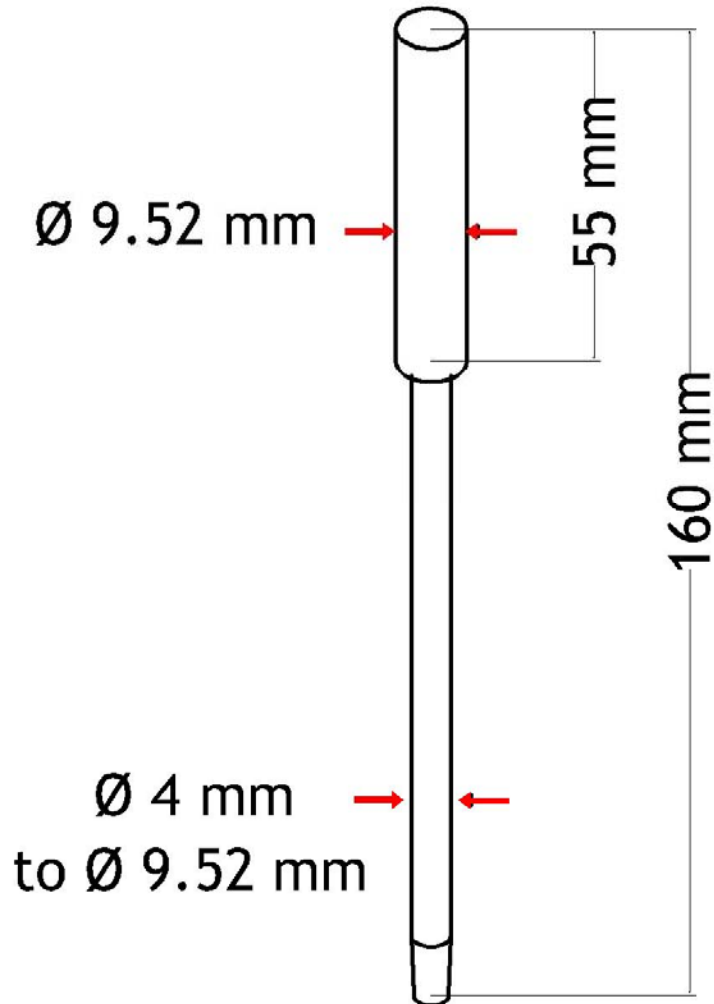

ONLY

TOOL HOLDER:

- SH-100
- SH-102
- SH-200
- SH-300
- SH-400

CPL

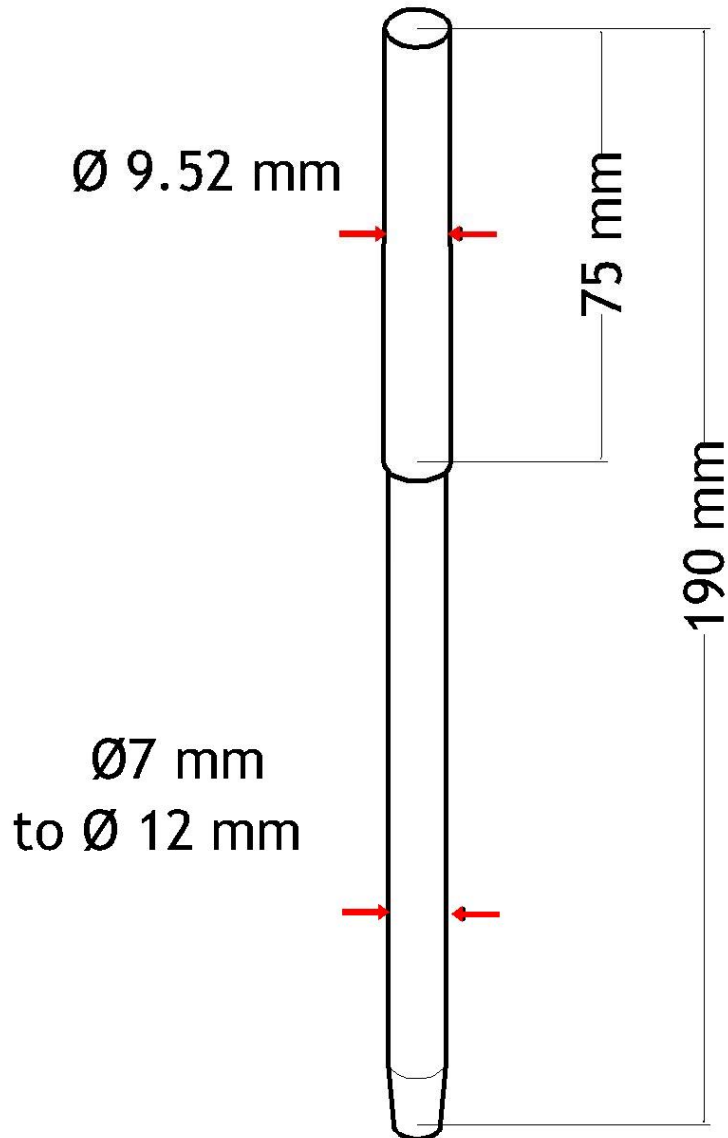

ONLY

TOOL HOLDER:

- SH-100
- SH-102
- SH-200
- SH-300
- SH-400

CPXL

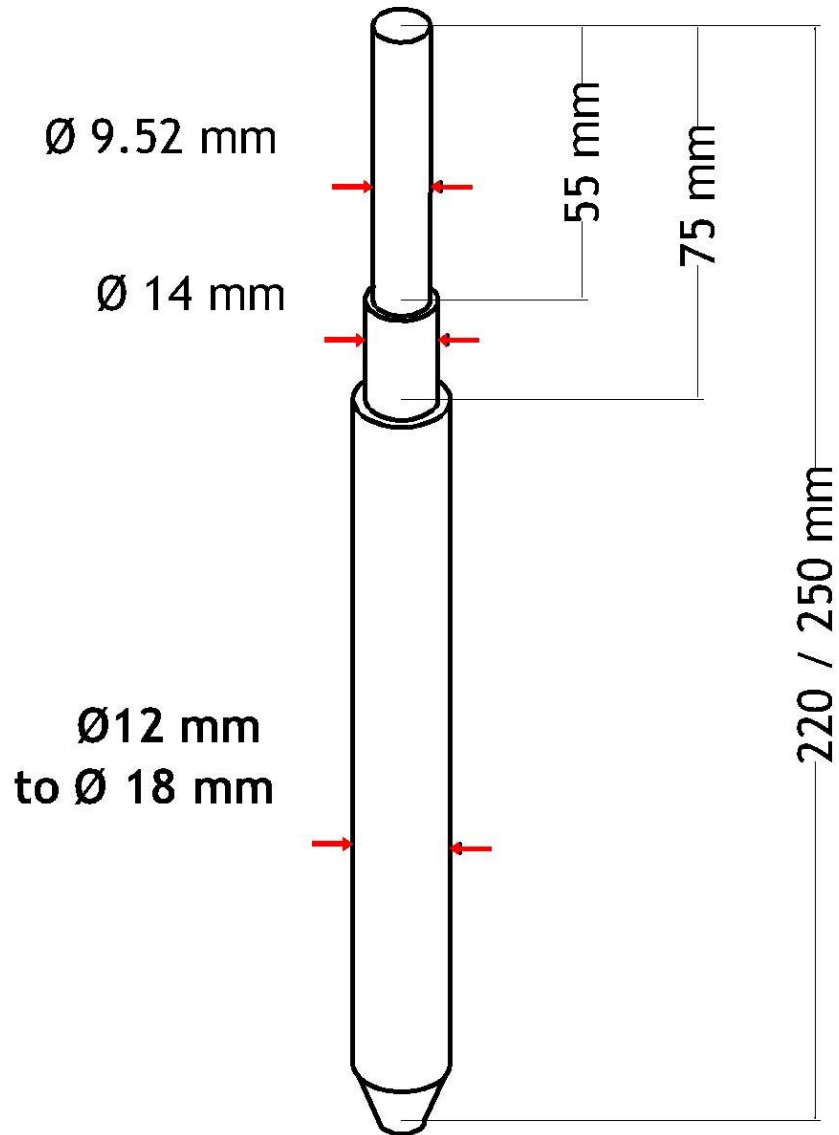

ONLY

TOOL HOLDER:

- SH-100
- SH-102
- SH-200
- SH-300
- SH-400

CARBIDE PILOTS

CPB

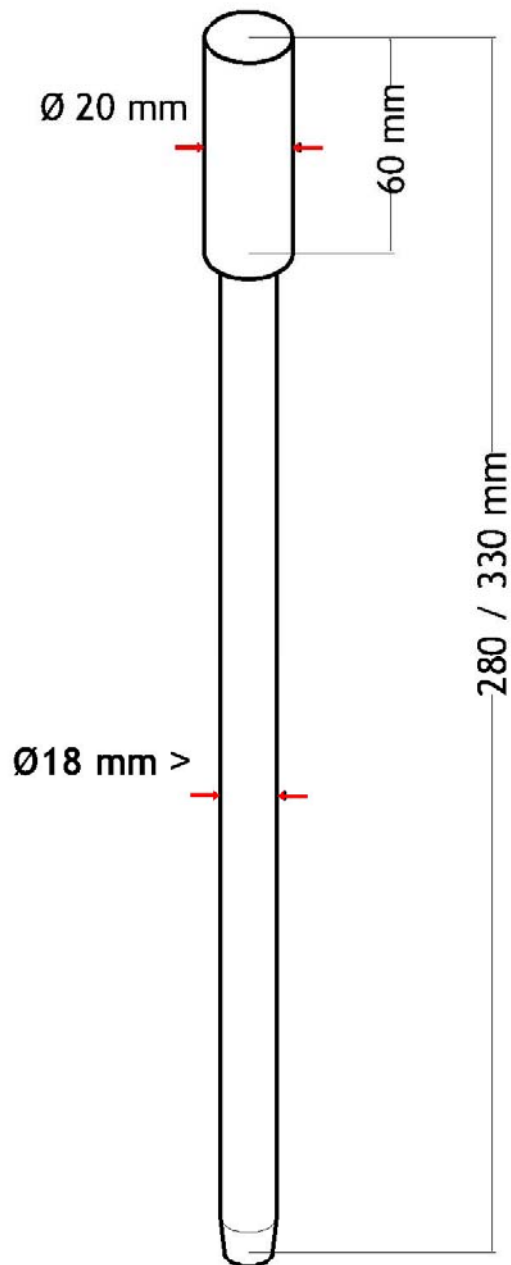

ONLY

TOOL HOLDER:
-SH-500



PROVALVE

İvedik Organize Sanayi Bölgesi 1548.Sokak No:21-23

06378 Yenimahalle / ANKARA – TURKEY

Tel : +90 312 395 39 65 / +90 312 395 39 66

Mobil : +90 507 923 89 03

Fax: +90 312 395 41 69

USER FRIENDLY AND HIGH EFFICIENCY MACHINES